

Rear Door Window Glass Adjustment

Special Tool(s) / General Equipment

Flat Headed Screw Driver

Adjustment

NOTE: Left hand (LH) shown, right hand (RH) similar.

NOTE: Removal steps in this procedure may contain installation details.

All adjustments

- NOTE:** This step is only necessary when the rear door has been replaced.

NOTE: The rear door must be aligned correctly before adjusting the rear door window glass.

Check the rear door alignment.

Refer to: [Rear Door Alignment](#) (501-03 Body Closures, General Procedures).

Up/Down, Fore/Aft adjustment

- Apply tape to top of the rear door window glass at the specified locations.
 - Apply tape on rear door window glass at the C-pillar 80 mm (3.149 in) from the rear top edge of the rear door window glass and make a reference mark on the tape to take measurements from.
 - Apply tape on rear door window glass at the B-pillar 25 mm (0.984 in) from the front top edge of the rear door window glass and make a reference mark on the tape to take measurements from.



- Open the rear door.

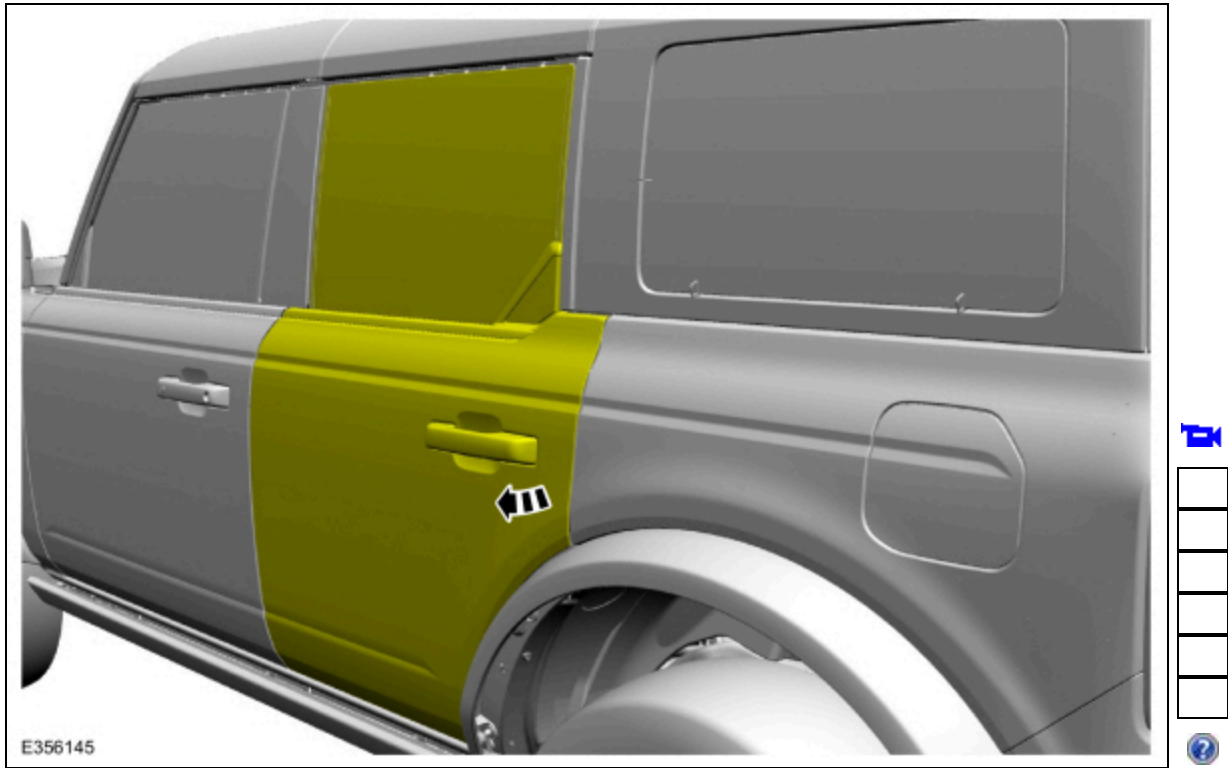

4. Measure the distance of the marks on the tape at both locations to the top edge of the rear door window glass at the specified locations.
1. Measure the rear door window glass at the C-pillar 80 mm (3.149 in) from the rear top edge of the rear door window glass and record.
 2. Measure the rear door window glass at the B-pillar 25 mm (0.984 in) from the front top edge of the rear door window glass and record.

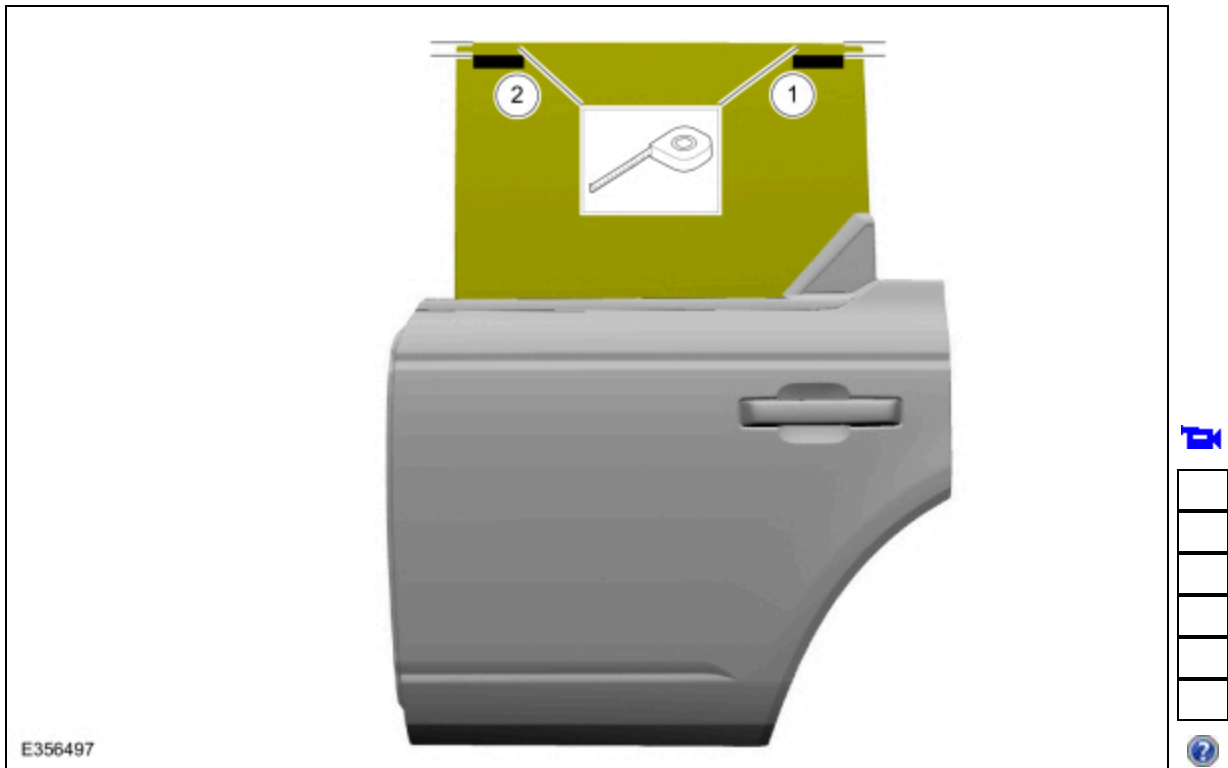

5. Close the rear door.

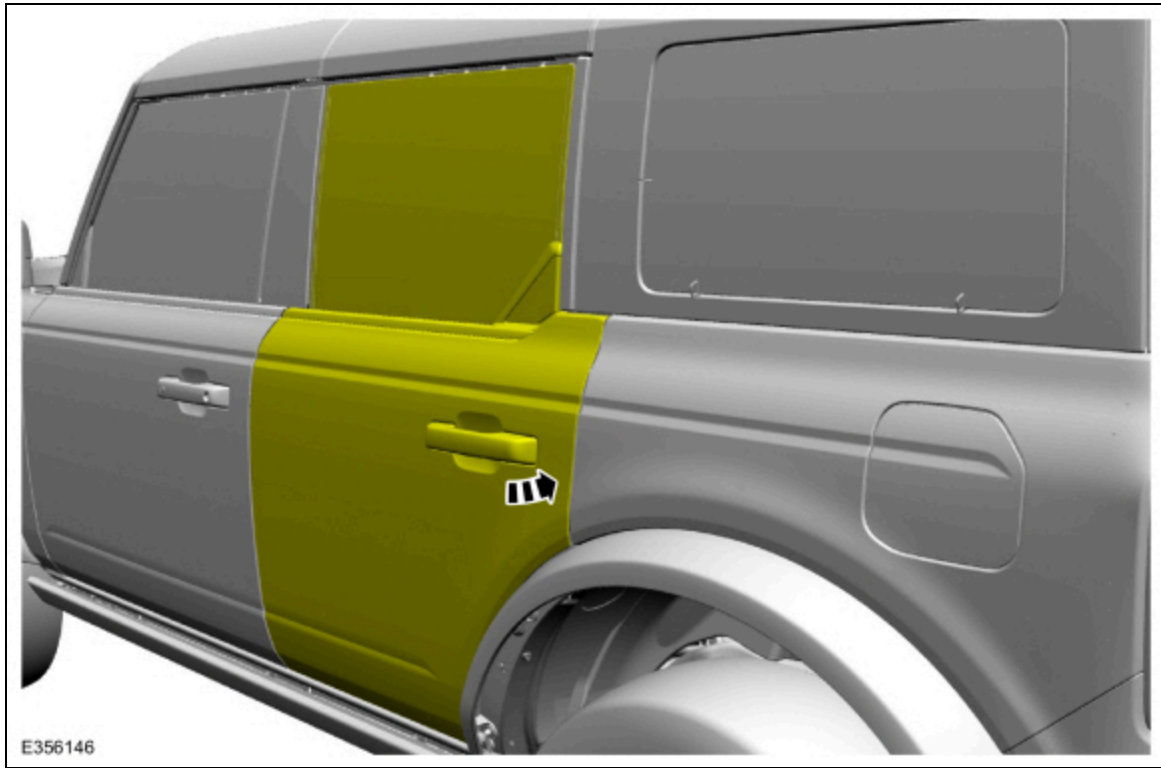

6. Measure the distance of the marks on the tape at both locations to the outer bottom edge of the seal retainer at the specified locations.
 1. Measure the rear door window glass at the C-pillar 80 mm (3.149 in) from the front top edge of the rear door window glass and record.
 2. Measure the rear door window glass at the B-pillar 25 mm (0.984 in) from the front top edge of the rear door window glass and record.



7. Subtract the distance of the marks on the tape at both locations from the previously recorded measurements in step 4.
 1. Rear door window glass engagement measurement range at the C-pillar 80 mm (3.149 in) from the rear top edge of the rear door window glass range is 3 mm (0.118 in) +/-2 mm (0.078).

2. Rear door window glass engagement measurement range at B-pillar 25 mm (0.984 in) from the front top edge of the rear door window glass range is 3 mm (0.118 in) +/-2 mm (0.078).

8. Open the rear door.

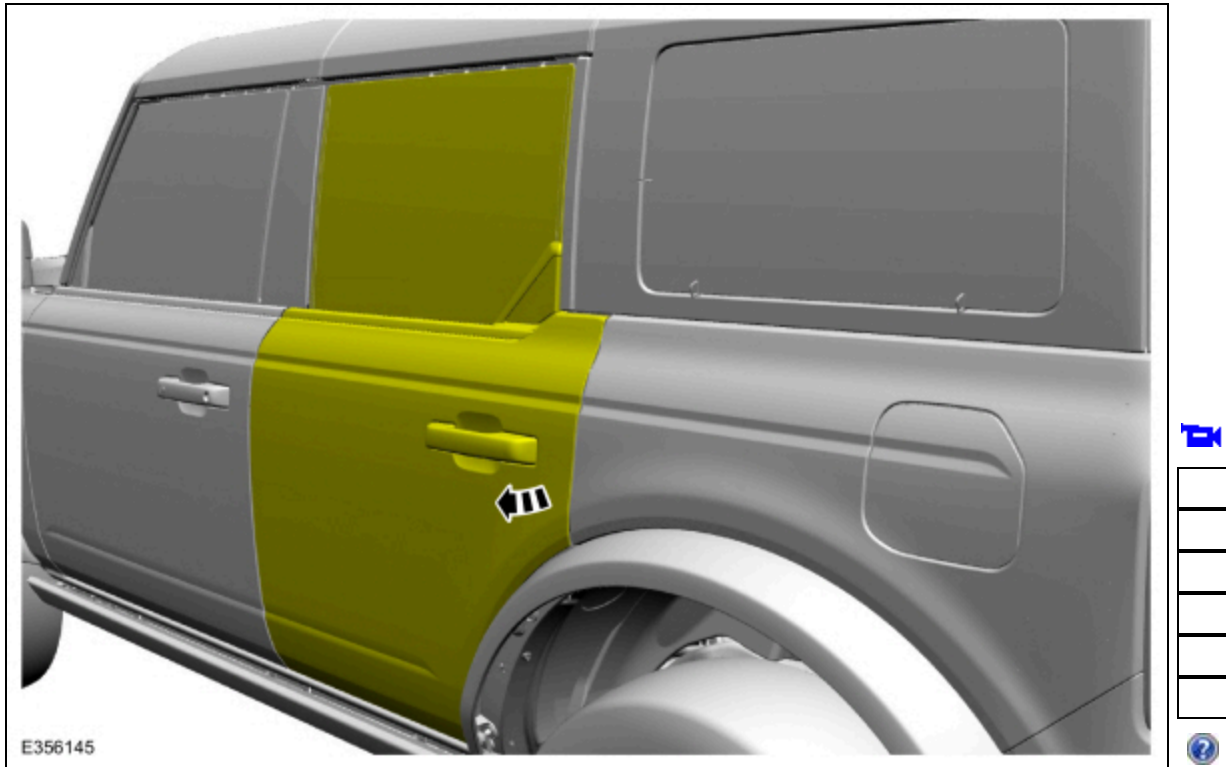

9. Remove the rear door trim panel.

Refer to: [Rear Door Trim Panel](#) (501-05 Interior Trim and Ornamentation, Removal and Installation).

10. **NOTE:** *The rear door shown removed for clarity.*

Remove the rear door window glass adhesive covers.

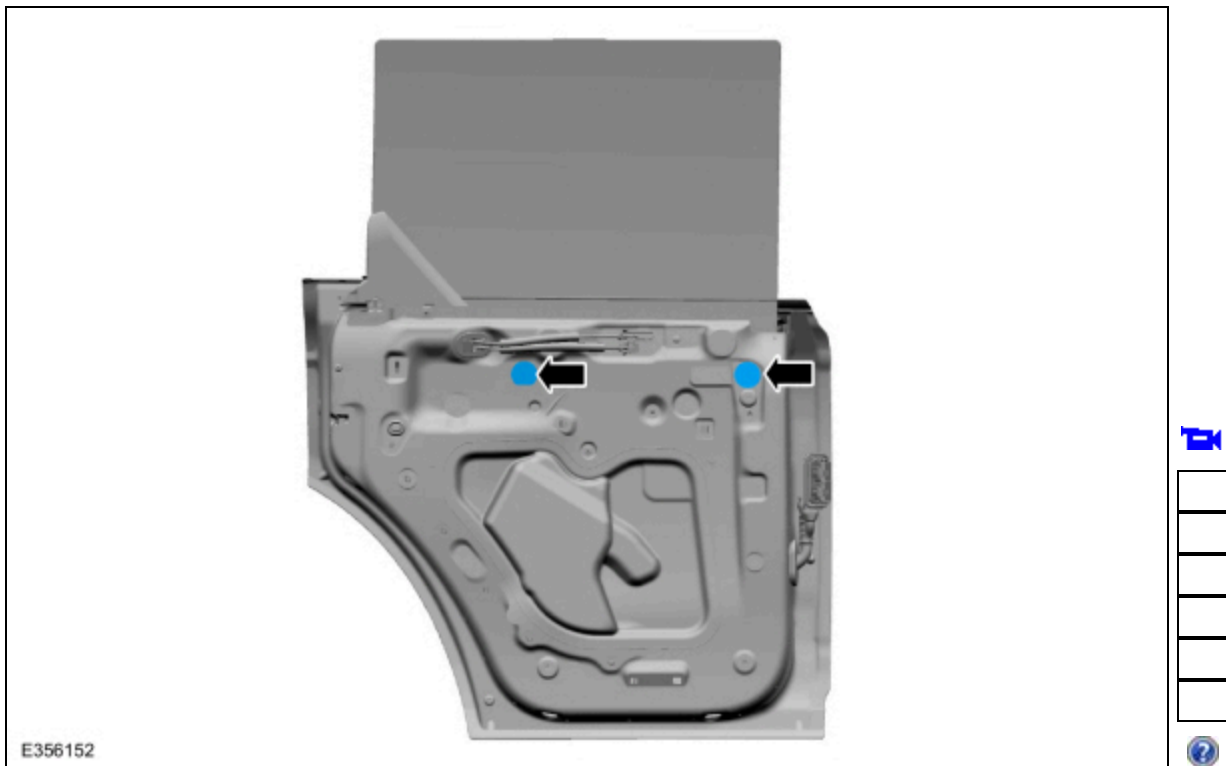

11. **NOTICE: Make sure to release the rear door latch to the open position before closing the rear door. Damage to the rear door latch may occur.**

NOTE: *The rear door shown removed for clarity.*

Raise and align the rear door window glass.

1. Position the rear door latch in to the closed position and the rear door window glass will raise to the full up position.
Use the General Equipment: Flat Headed Screw Driver
2. Confirm the rear door window glass screws are aligned with the access openings.

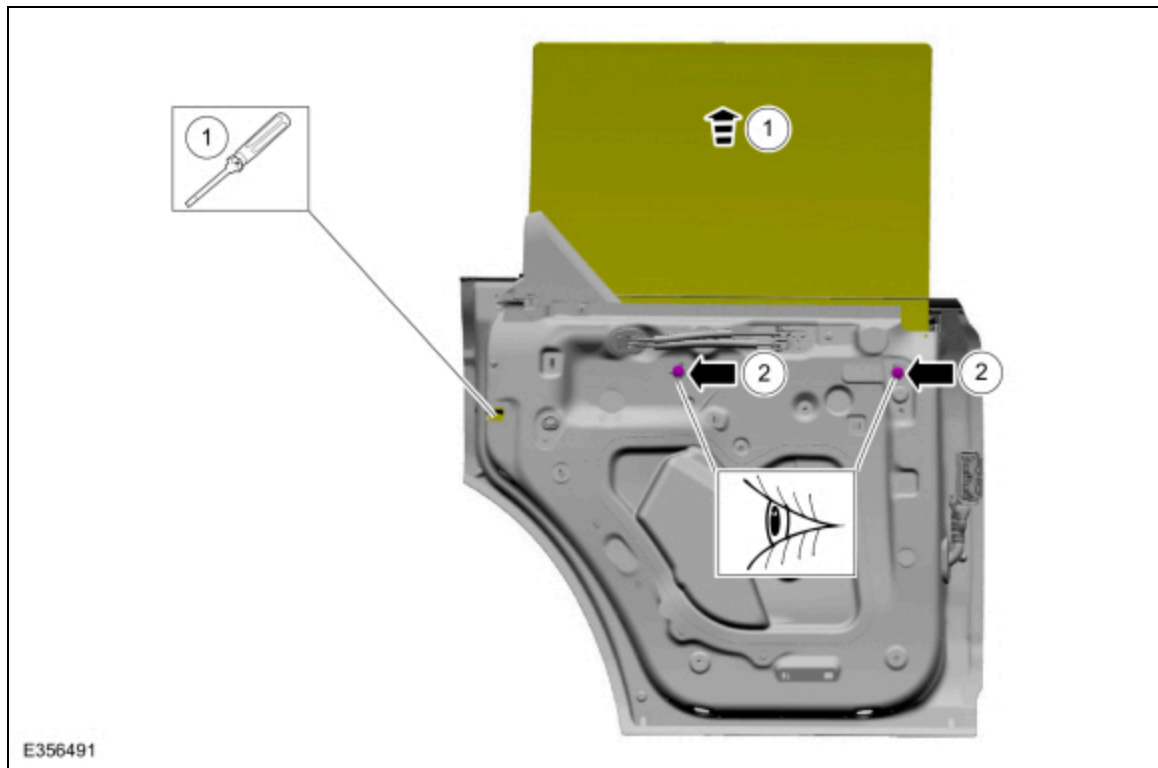

12. **NOTICE: Make sure to release the rear door latch to the open position before closing the rear door. Damage to the rear door latch may occur.**

NOTE: *The rear door shown removed for clarity.*

1. Loosen both rear door window glass screws, adjust the rear door window glass as necessary and tighten both rear door window glass screws.
Torque: 93 lb.in (10.5 Nm)
2. Position the rear door latch in to the open position.
Use the General Equipment: Flat Headed Screw Driver

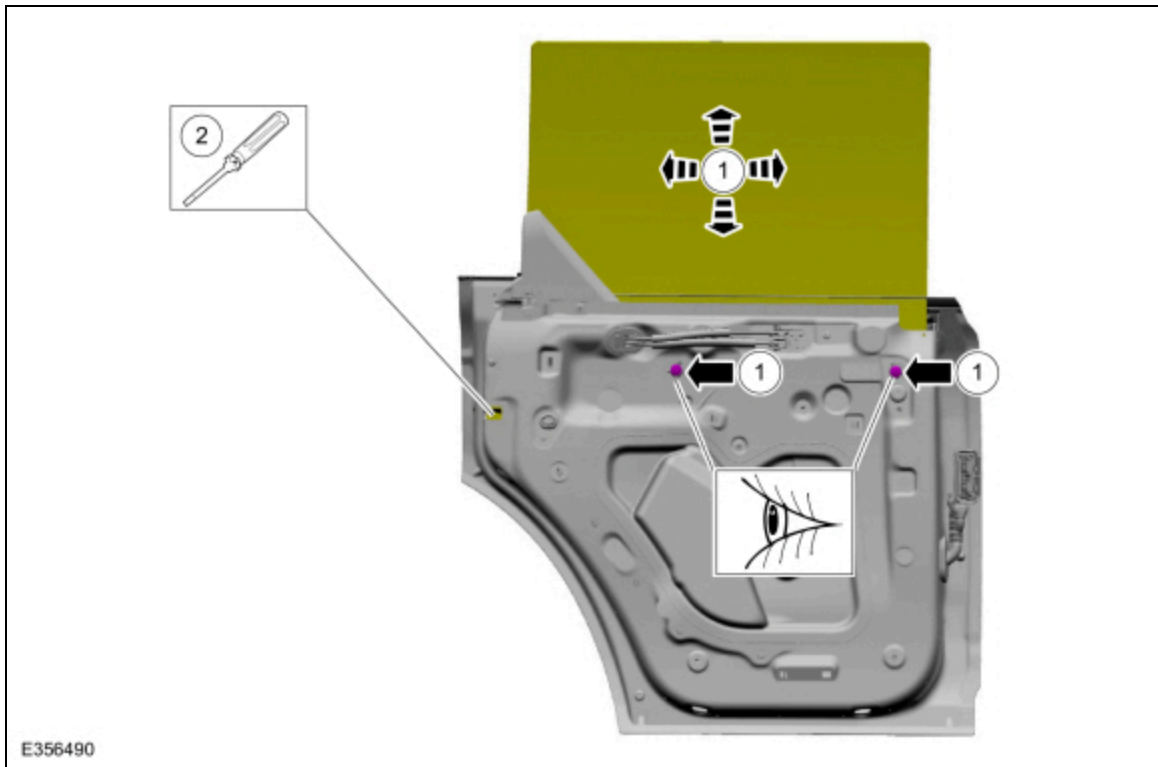

13. Close the door.

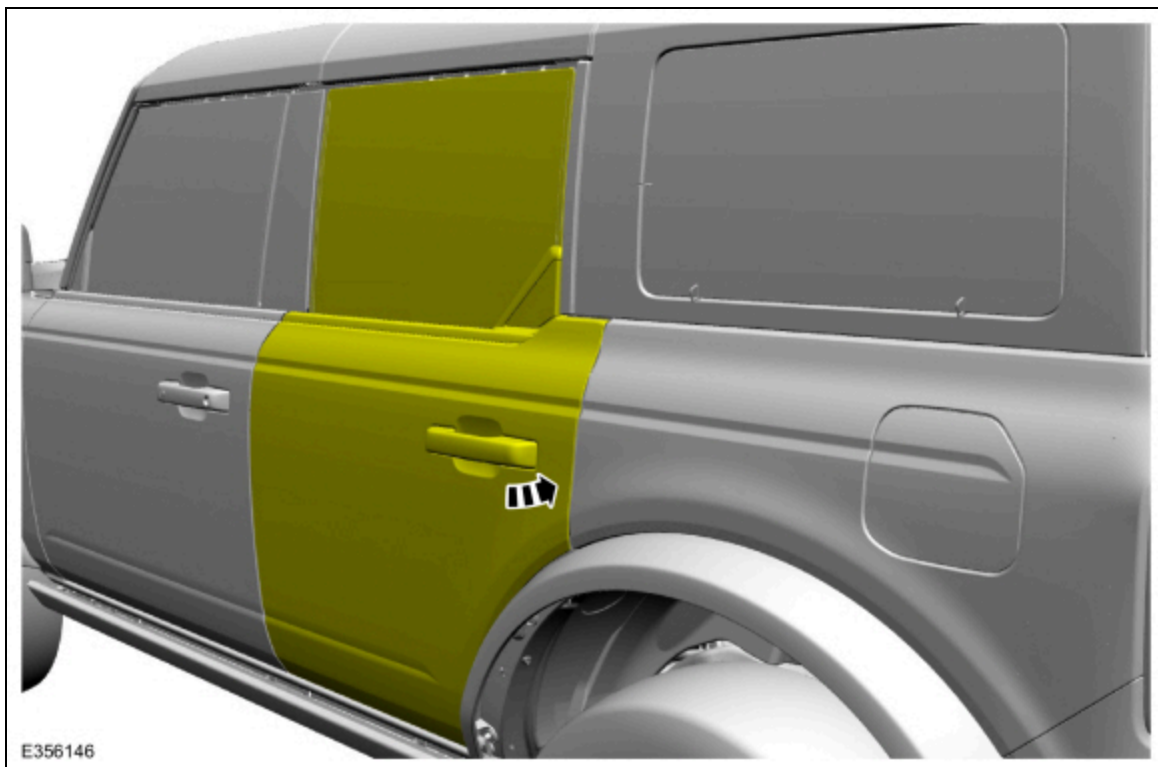

14. Measure the distance of the marks on the tape at both locations to the outer bottom edge of the seal retainer at the specified locations.
- 1. Measure the rear door window glass at the C-pillar 80 mm (3.149 in) from the rear top edge of the rear door window glass and record.
 - 2. Measure the rear door window glass at the B-pillar 25 mm (0.984 in) from the front top edge of the rear door window glass and record.

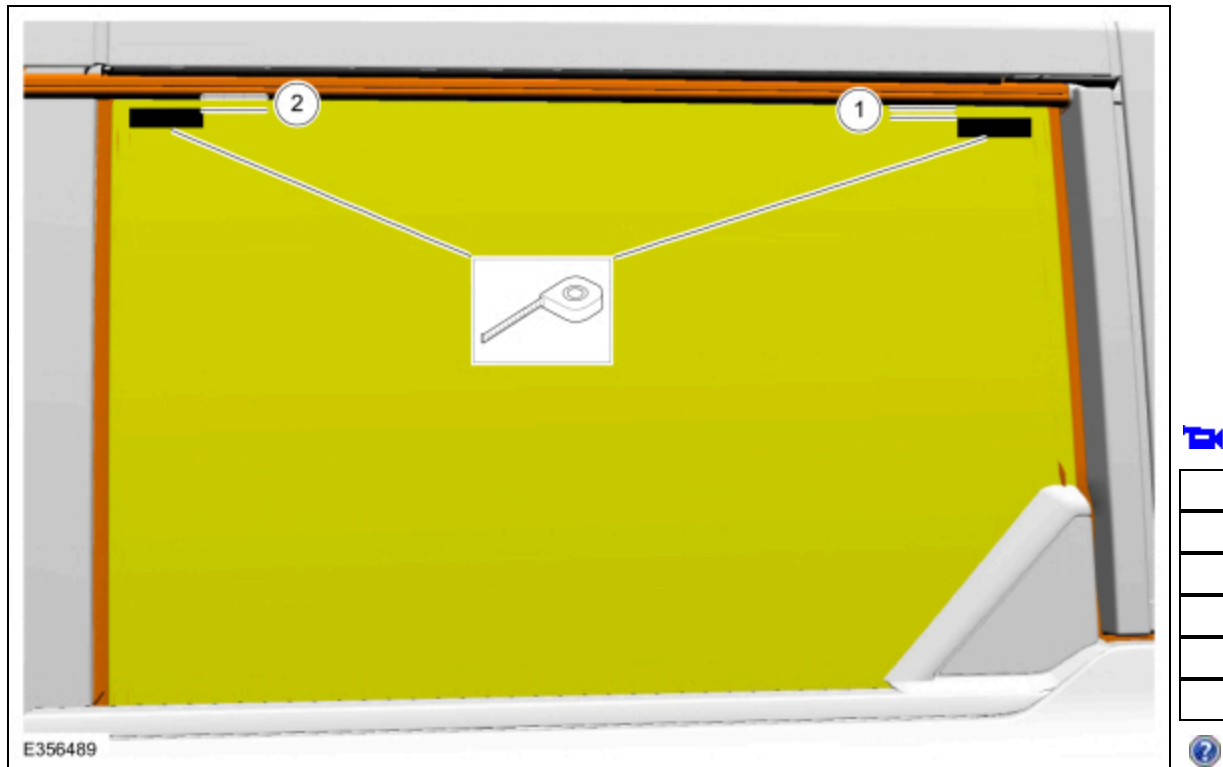

15. **NOTE:** Repeat steps 11 through 15 until the rear door window glass within specification.

Subtract the distance of the marks on the tape at both locations from the previously recorded measurements in step 4.

1. Rear door window glass engagement measurement range at the C-pillar 80 mm (3.149 in) from the rear top edge of the rear door window glass range is 3 mm (0.118 in) +/-2 mm (0.078).
2. Rear door window glass engagement measurement range at B-pillar 25 mm (0.984 in) from the front top edge of the rear door window glass range is 3 mm (0.118 in) +/-2 mm (0.078).
3. Measure the rear door window glass gap between the C-pillar and the rear edge of the rear door window glass. When the glass is adjusted correctly the gap should be 10 mm (0.393 in) +/-2.6 mm (0.102) the entire length of the rear edge of the rear door window glass.
4. Measure the rear door window glass gap between the B-pillar and the front edge of the rear door window glass. When the glass is adjusted correctly the gap should be 10 mm (0.393 in) +/-2.6 mm (0.102) the entire length of the front edge of the rear door window glass.

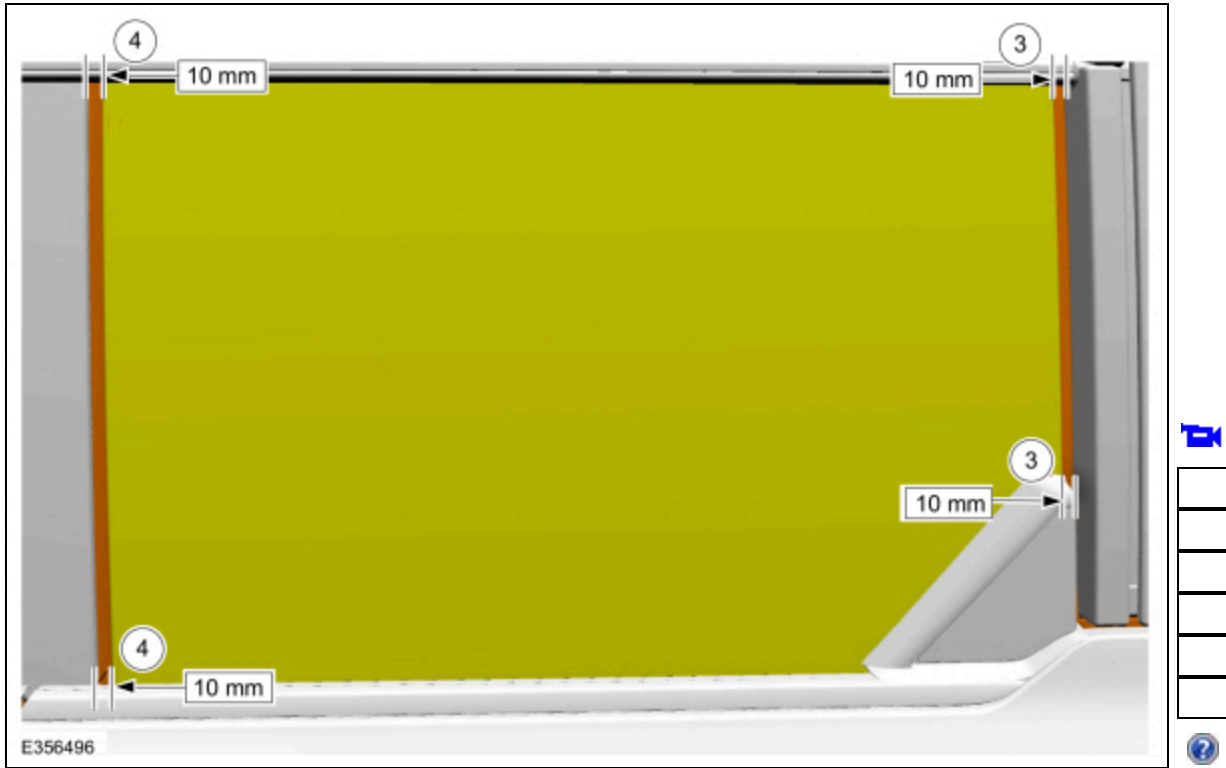

In/Out adjustment

- 16. Lower and raise the rear door window glass and check the glass engagement into the weatherstrip at the specified locations.



- 17. Open the rear door.

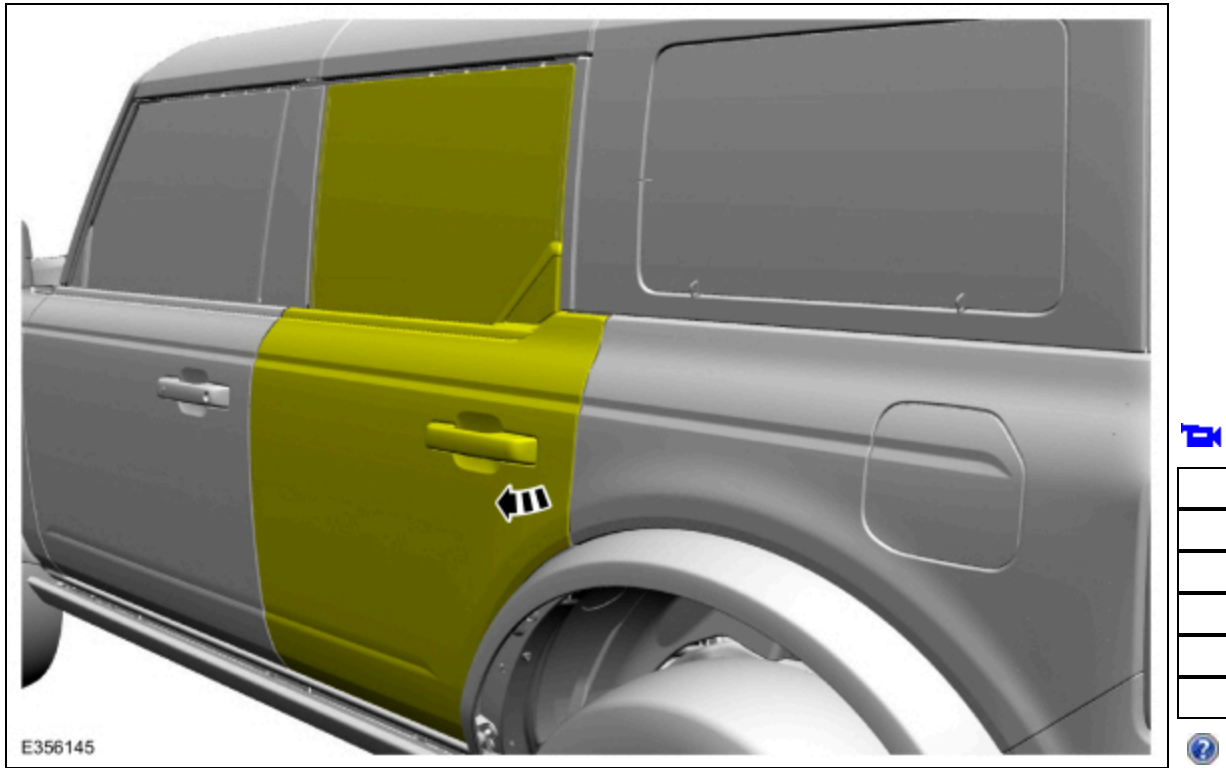

18. **NOTE:** *The rear door shown removed for clarity.*

Remove the lower rear door window regulator access plugs.

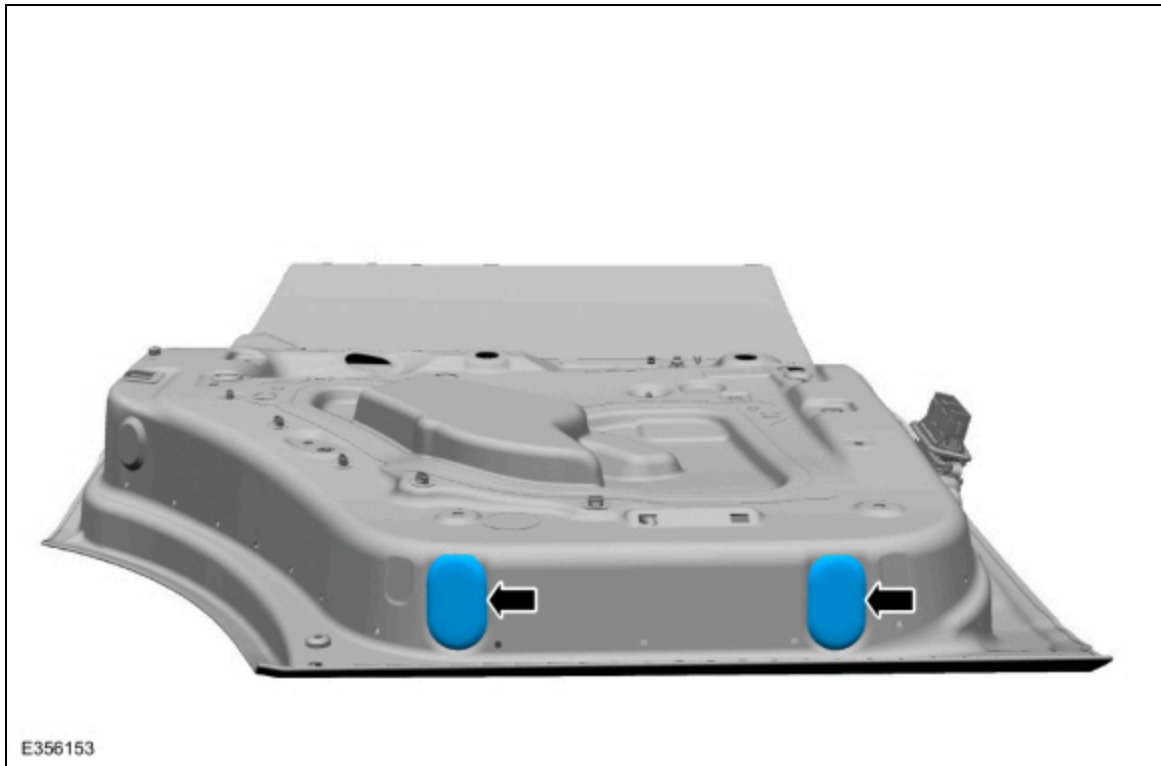

19. **NOTE:** *The rear door shown removed for clarity.*

Remove the aft rear door glass run and bracket access plug.

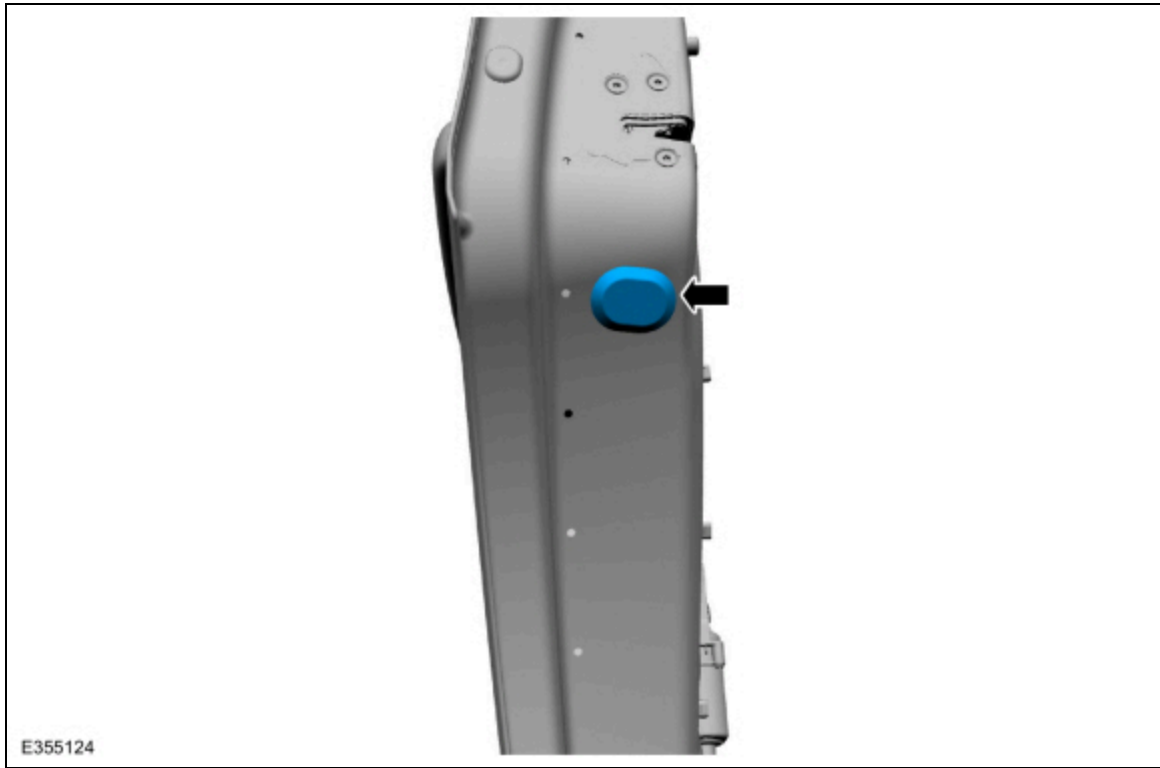

20. **NOTE:** *The rear door shown removed for clarity.*

Remove the rear door watershield.

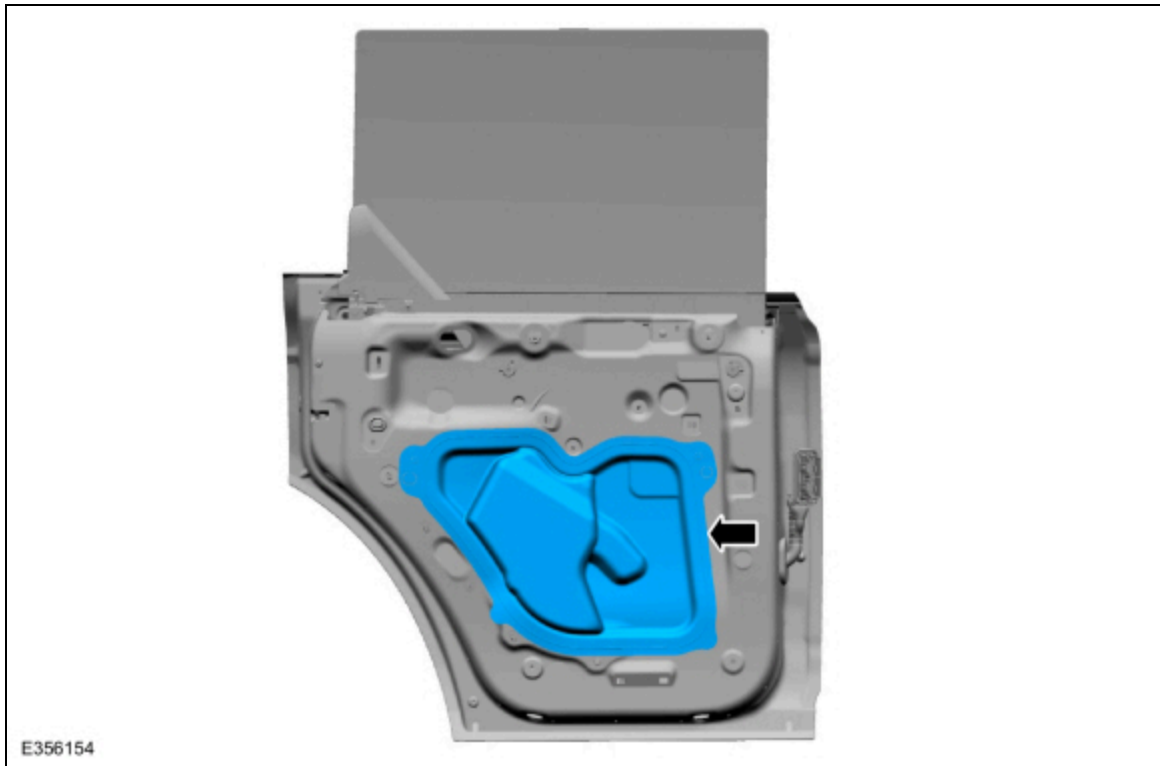

21. **NOTE:** *The rear door shown removed for clarity.*

NOTE: *Make sure to mark the location of the lower rear door window regulator nuts position to aid alignment as a starting point reference.*

Loosen the lower rear door window regulator nuts.

1. Mark around the lower rear door window regulator nuts with a marker.

2. Loosen the lower rear door window regulator nuts.

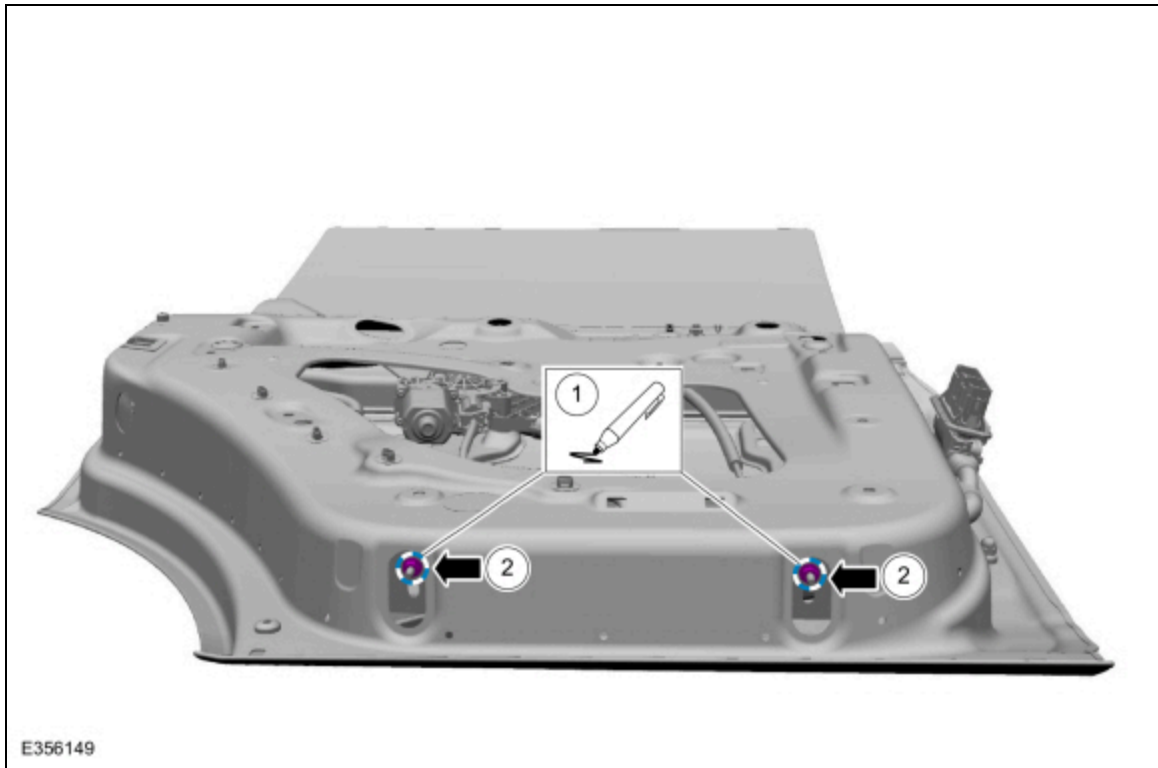

22. **NOTE:** The rear door shown removed for clarity.

NOTE: Make sure to mark the location of the aft rear door glass run and bracket lower nut position to aid alignment as a starting point reference.

Loosen the lower aft rear door glass run and bracket nut.

1. Mark the location of lower aft rear door glass run and bracket nut.
2. Loosen the lower aft rear door glass run and bracket nut.

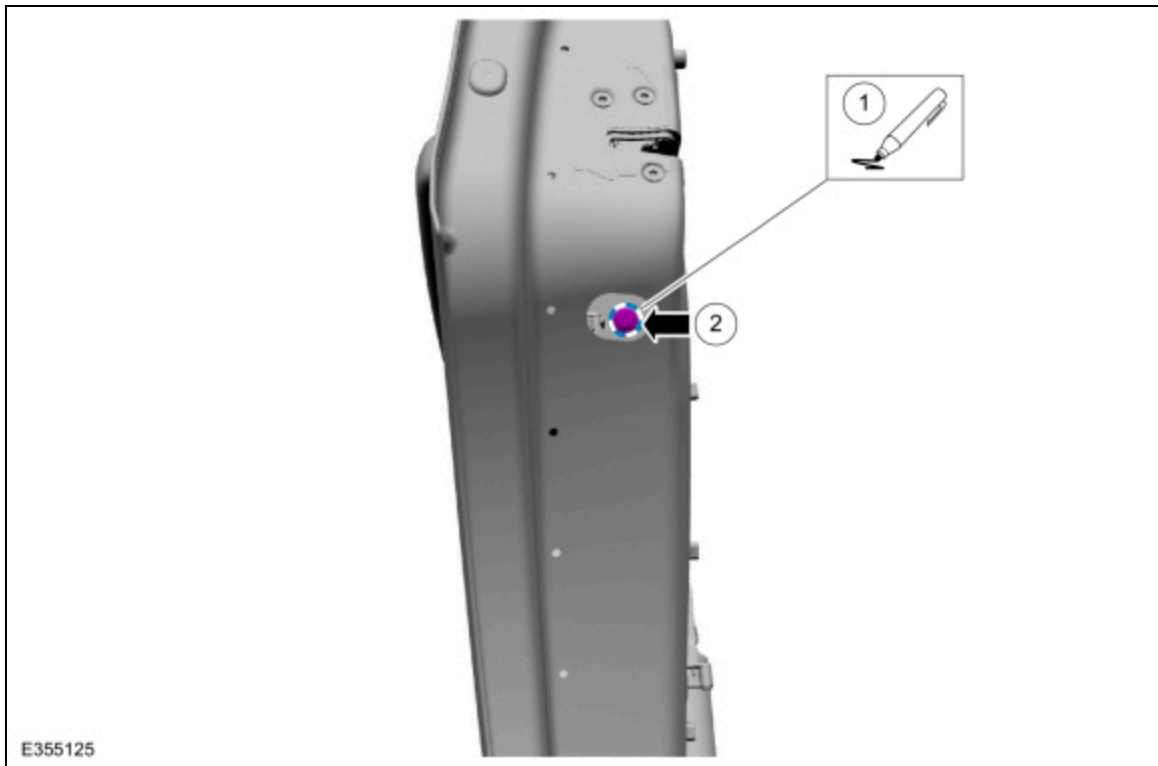

23. **NOTE:** The rear door shown removed for clarity.

NOTE: The rear door shown transparent for clarity.

NOTE: Adjust the rear door window regulator rails equally in and out to avoid binding.

NOTE: Start with rear door window regulator rails in the neutral position as starting point reference. Add more or less tip and or out as needed. The neutral state would put the studs about 60% of the way to the outboard side of the door in the adjustment slots.

Adjust the rear door window regulator rails to achieve more or less tip in at the top of the rear door window glass.

1. Adjust the rear and rear regulator rails equally in and out to avoid binding and tighten the lower rear door window regulator nuts.
Torque: 71 lb.in (8 Nm)
2. Adjust and tighten the lower aft rear door glass run and bracket nut.
Torque: 71 lb.in (8 Nm)

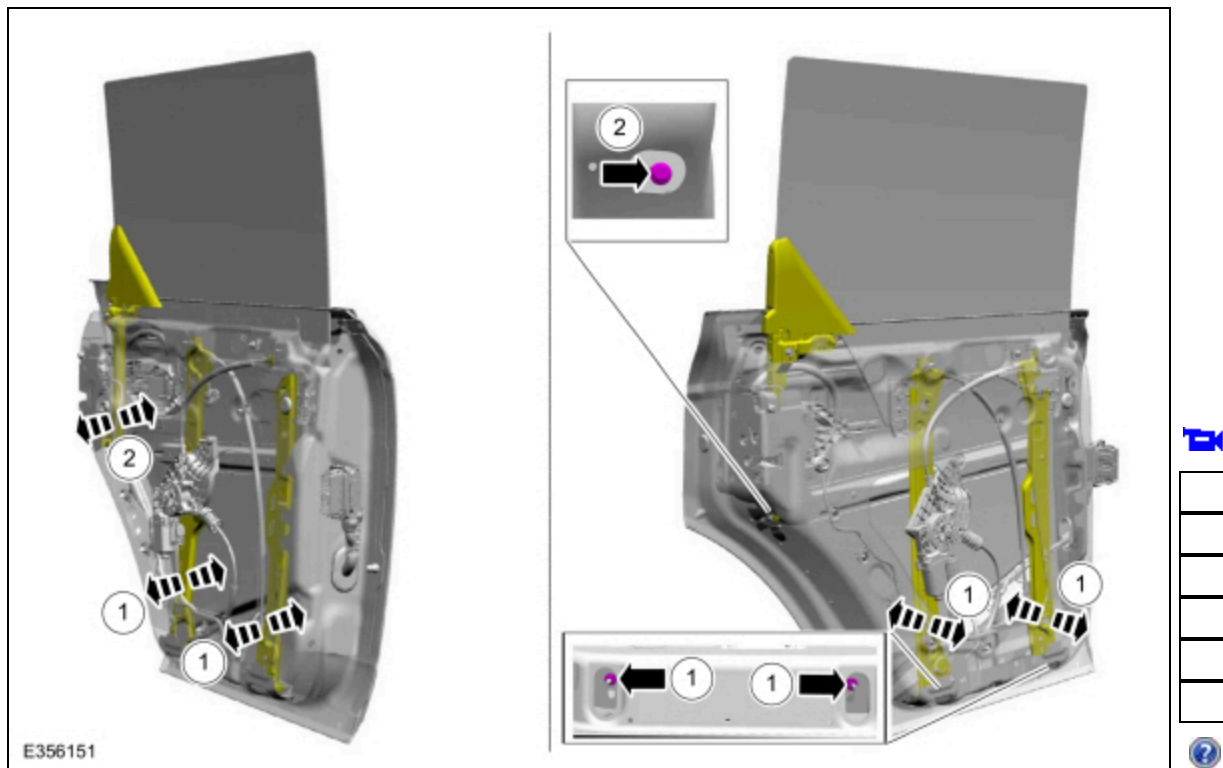

24. Close the rear door.

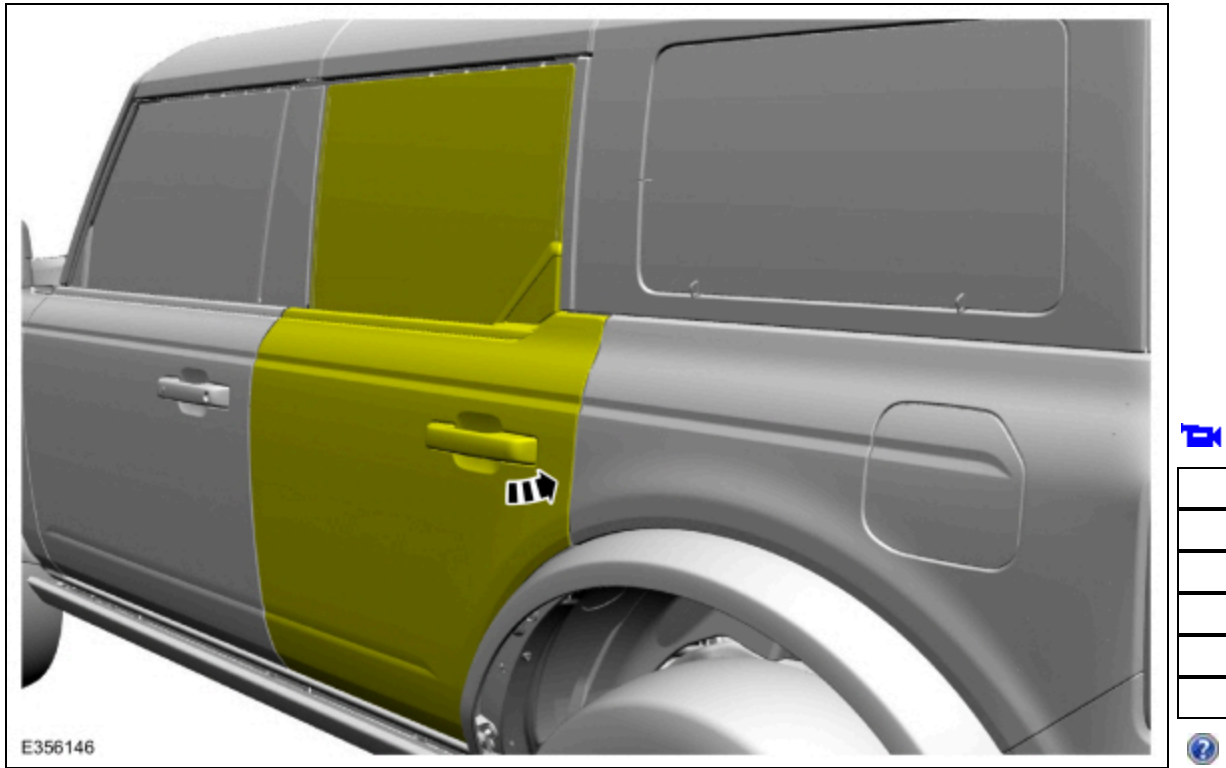

25. **NOTE:** Repeat steps 21 through 25 until the rear door window glass within specification.

Lower and raise the rear door window glass and check the glass engagement into the weatherstrip at the specified locations.



All adjustments

26. Open the rear door.

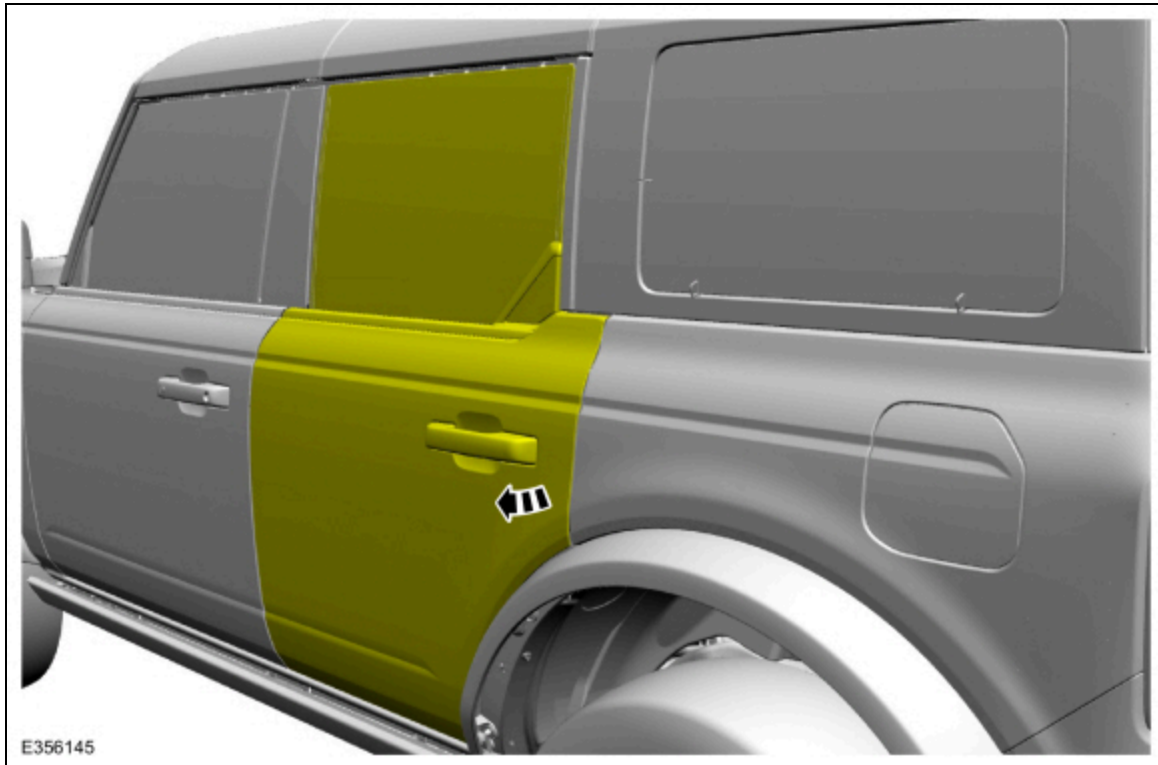

27. **NOTE:** *The rear door shown removed for clarity.*

Measure the distance of the marks on the tape at both locations to the top edge of the rear door glass at the specified locations.

1. Measure the rear door window glass at the C-pillar 80 mm (3.149 in) from the rear top edge of the rear door window glass and record.
2. Measure the rear door window glass at the B-pillar 25 mm (0.984 in) from the front top edge of the rear door window glass and record.

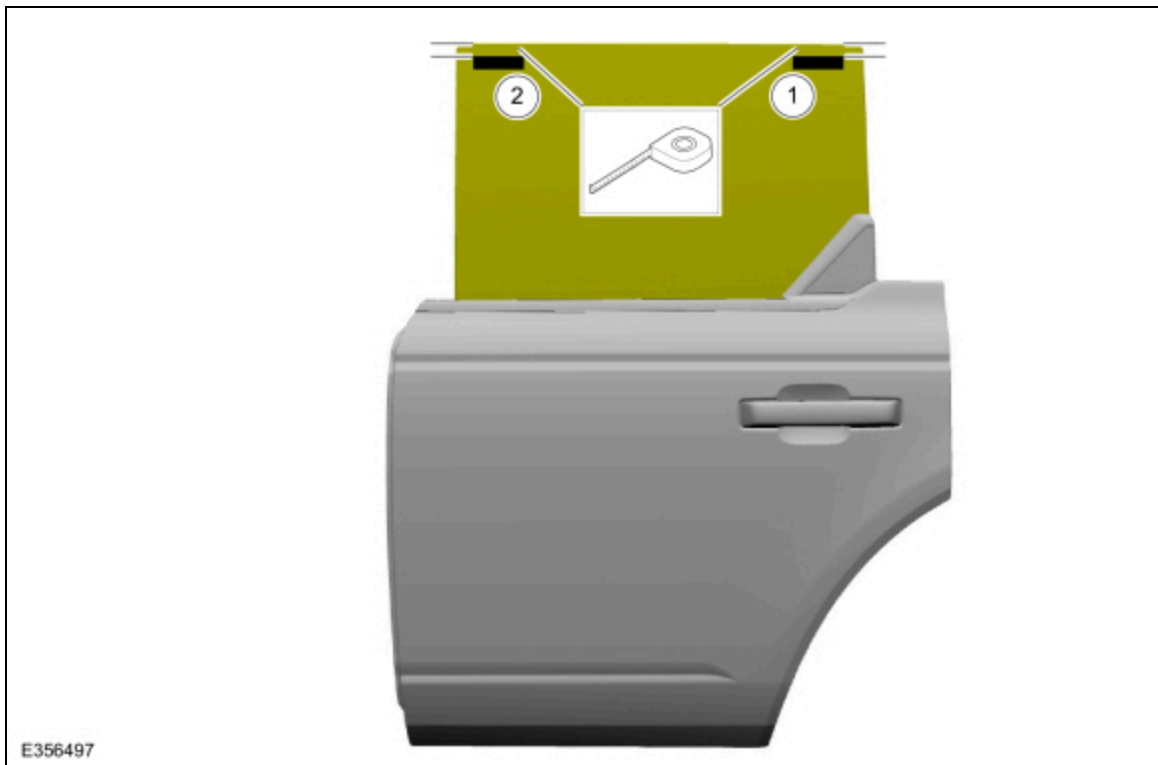

28. Close the rear door.

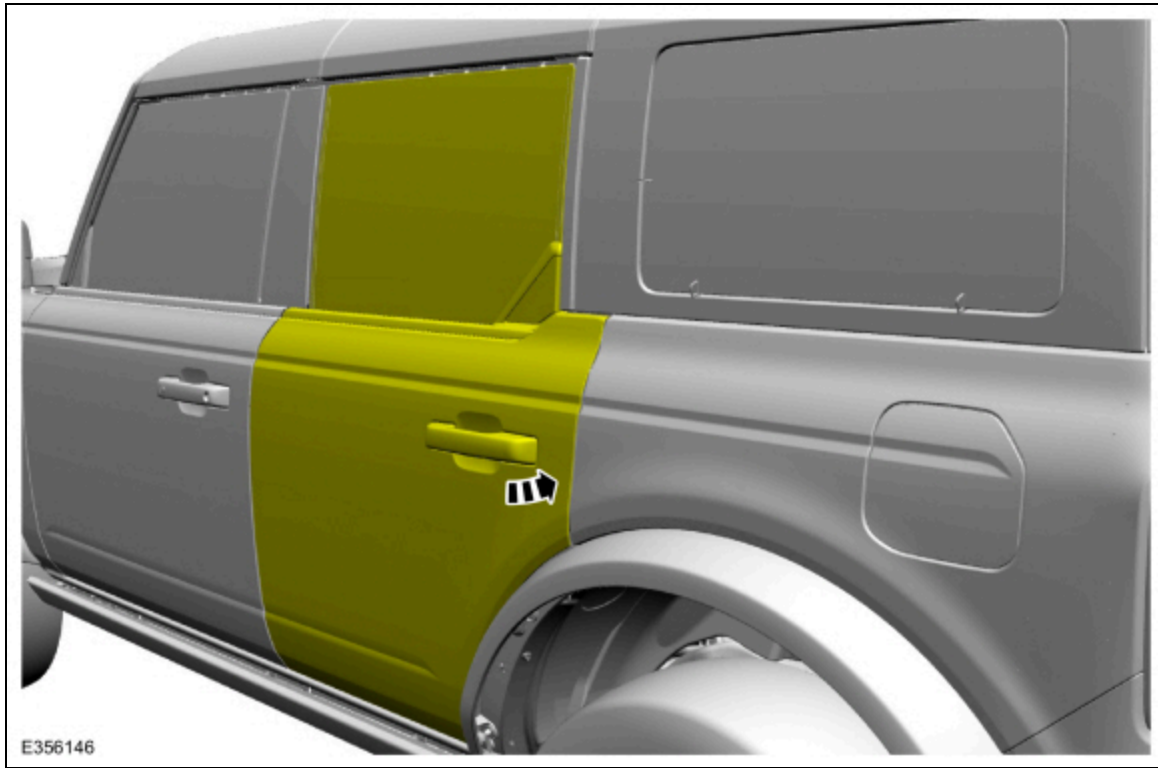

29. Measure the distance of the marks on the tape at both locations to the outer bottom edge of the seal retainer at the specified locations.
1. Measure the rear door window glass at the C-pillar 80 mm (3.149 in) from the rear top edge of the rear door window glass and record.
 2. Measure the rear door window glass at the B-pillar 25 mm (0.984 in) from the front top edge of the rear door window glass and record.



30. **NOTE:** Repeat steps 11 through 15 until the rear door window glass within specification.

Subtract the distance of the marks on the tape at both locations from the previously recorded measurements in step 4.

1. Rear door window glass engagement measurement range at the C-pillar 80 mm (3.149 in) from the rear top edge of the rear door window glass range is 3 mm (0.118 in) +/-2 mm (0.078).
2. Rear door window glass engagement measurement range at B-pillar 25 mm (0.984 in) from the front top edge of the rear door window glass range is 3 mm (0.118 in) +/-2 mm (0.078).
3. Measure the rear door window glass gap between the C-pillar and the rear edge of the rear door window glass. When the rear door window glass is adjusted correctly the gap should be 10 mm (0.393 in) +/-2.6 mm (0.102) the entire length of the rear edge of the rear door window glass.
4. Measure the rear door window glass gap between the B-pillar and the front edge of the rear door window glass. When the rear door window glass is adjusted correctly the gap should be 10 mm (0.393 in) +/-2.6 mm (0.102) the entire length of the front edge of the rear door window glass.

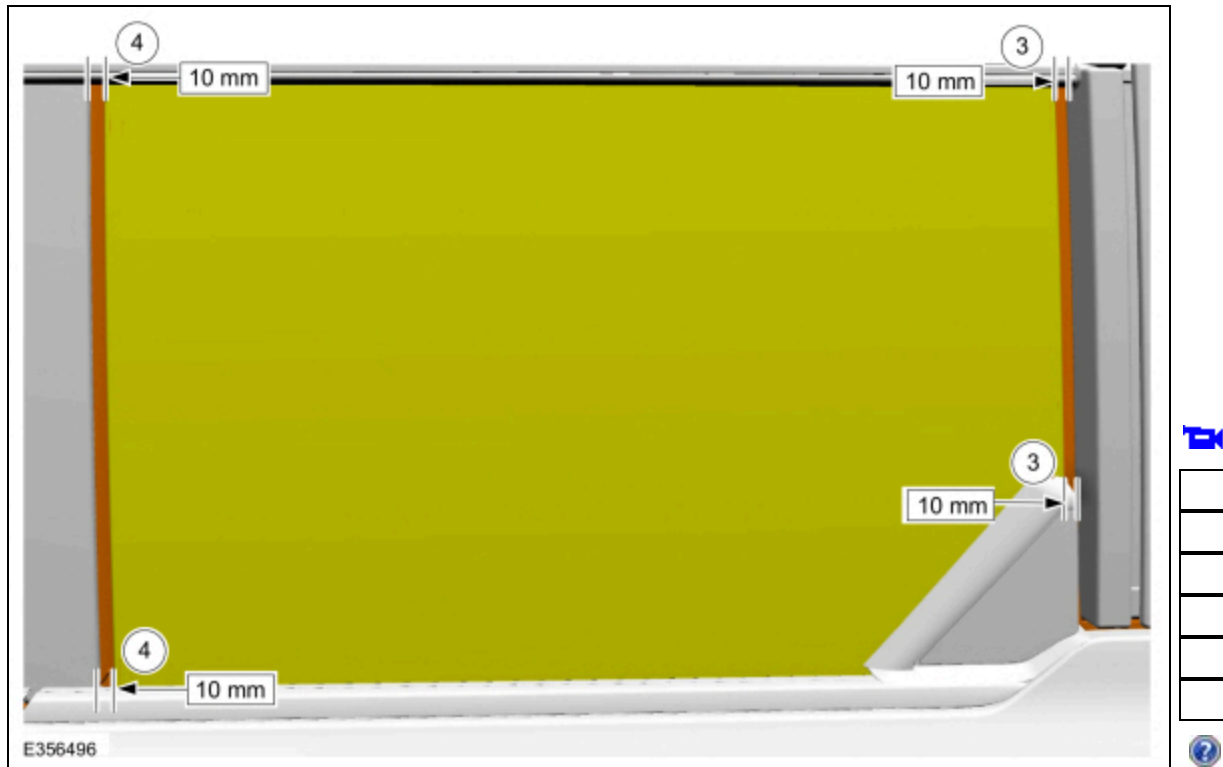

31. **NOTE:** Repeat steps 21 through 25 until the rear door window glass within specification.

Lower and raise the rear door window glass and check the glass engagement into the weatherstrip at the specified locations.

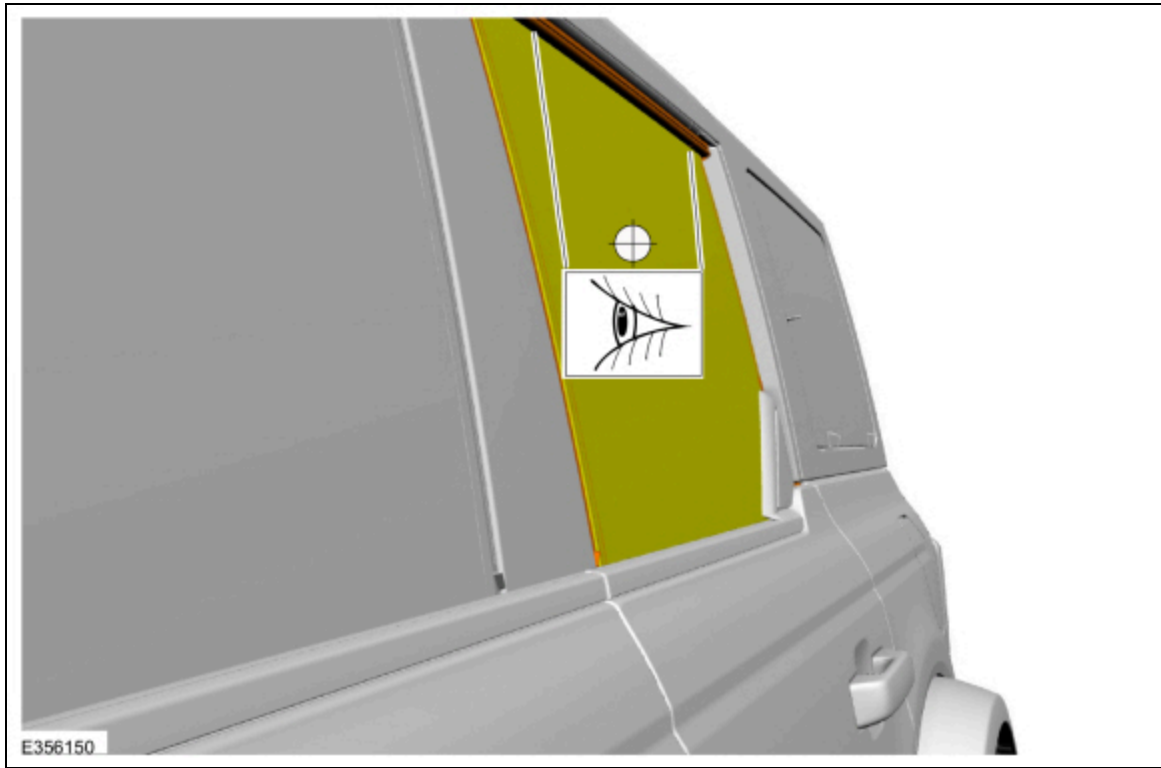

32. Remove the tape from the rear door window glass.

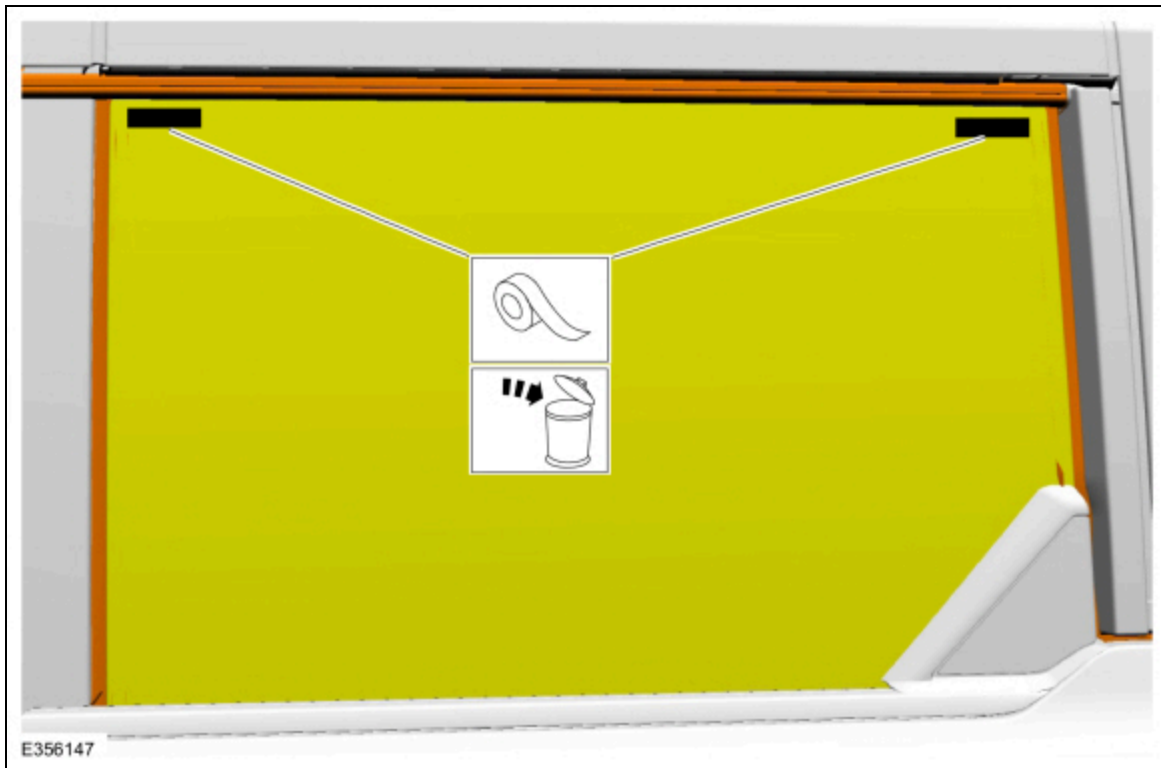

33. Install the removed components.

© Copyright 2024, Ford Motor Company.

