

## Ford Bronco

### Electric Brake Controller

### Régulateur de freinage









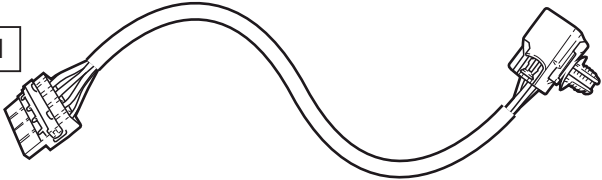
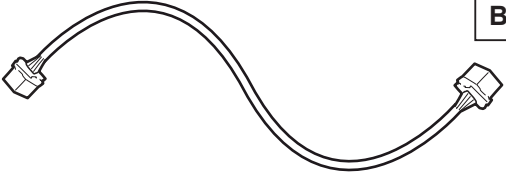
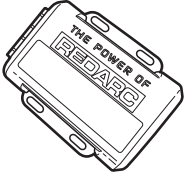
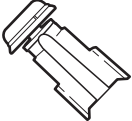

### Controlador de freno eléctrico

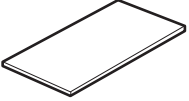
Kit Part No  
N° de référence du kit  
N.º de pieza del kit

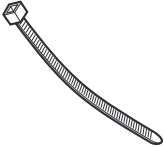

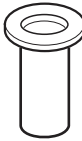
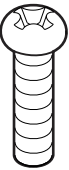



**VM2DZ-2C006-A**

Fitting Time / Durée D'installation / Tiempo De Adaptación: 45 minutes

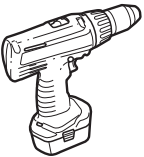
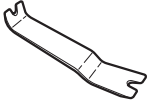
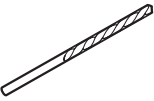

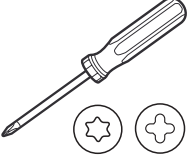
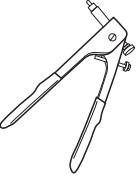
 <p><b>A</b> x 1</p>		 <p><b>B</b> x 1</p>	
 <p><b>C</b> x 1</p>	 <p><b>D</b> x 1</p>	 <p><b>E</b> x 1</p>	 <p><b>F</b> x 1</p>
 <p><b>G</b> x 2</p>	 <p><b>H</b> 200mm x 10</p>	 <p><b>I</b> x 1</p>	 <p><b>J</b> x 1</p>
 <p><b>K</b> x 1</p>	 <p><b>L</b> x 1</p>	 <p><b>M</b> x 1</p>	 <p><b>N</b> x 1</p>



















**Tools Required / Outils nécessaires / Herramientas necesarias**

		 <p>Ø 5 mm</p>	 <p>Ø 25 mm</p>	
				

abc	EN	Description	FR	La description	ES	Descripción	
<b>A</b>		Harness		Harnais		Cables	1
<b>B</b>		Switch Cable		Câble De Commutation		Cable De Interruptor	1
<b>C</b>		REDARC ECU		UCE REDARC		ECU REDARC	1
<b>D</b>		REDARC Switch		Commutateur REDARC		Interruptor REDARC	1
<b>E</b>		Bezel		Lunette		Bisel	1
<b>F</b>		Double Sided Tape 60X80X2.3 mm		Adhésif Double Face 60X80X2,3 mm		Cinta De Doble Cara De 60X80X2.3 mm	1
<b>G</b>		Cleaning Pad		Tampon De Nettoyage		Almohadilla De limpieza	2
<b>H</b>		200mm Cable Tie		Attache De Câble 200 mm		Cincho Para Cable De 200 mm	10
<b>I</b>		Foam Tape		Ruban-mousse adhésif		Cinta de hule espuma	1
<b>J</b>		Rivet Nut		Écrou-rivet		Tuerca remache	1
<b>K</b>		Screw		Vis		Tornillo	1
<b>L</b>		Spring Washer		rondelle élastique		Arandela elástica	1
<b>M</b>		Flat Washer		rondelle plate		Arandela plana	1
<b>N</b>		Fitting Instruction		Instructions De Montage		Instrucciones De Montaje	1



	BK	WH	GY	PK	RD	BU	YE	BN	VT	OG
<b>EN</b>	black	white	grey	pink	red	blue	yellow	brown	purple	orange
<b>ES</b>	negro	blanco	gris	rosa	rojo	azul	amarillo	marrón	violeta	naranja
<b>FR</b>	noir	blanc	gris	rose	rouge	bleu	jaune	brun	violet	orange

	EN	FR	ES
	Position/Location	Flèche de Position	Flecha de posición
	Movement	Flèche indiquant le sens du mouvement	Flecha de movimiento
	Connect	Connecter	Conecte
	Disconnect / detach	Déconnecter / détacher	Desconectar / quitar
	Loosen up	Desserrer	Alojar
	Tighter up	Serrer	Apretar
	See workshop manual	Voir le manuel d'atelier	Consulte el manual de taller
	Attention / important advice	Attention / indication importante	Atención / indicación importante
	Look at page nr. ...	Se référer à la page n° ...	Mirar en la página n°...
	Not present / not occupied / not OK	Pas disponible / pas occupé / pas OK	Non presente / non ocupado / non OK
	Positive connection battery terminal lug	Borne „plus" de la batterie	Conexión positiva de batería
	Ground connection battery terminal lug	Borne „moins" de la batterie	Conexión negativa de batería
	Torque	Couple	Par de torsión
	Turn around / rotate / from the other side	Retourner/pivoter/de l'autre côté	Dar la vuelta / rotar / desde el otro lado
	Vehicle with Manual Transmission only	Véhicule à boîte de vitesses manuelle uniquement	Vehículo con transmisión manual solamente
	Vehicle with Automatic Transmission only	Véhicule à boîte de vitesses automatique uniquement	Vehículo con transmisión automática solamente
	Optional / option	Facultatif/option	Opcional/opción
	Vehicle part	Pièce du véhicule	Pieza de vehículo

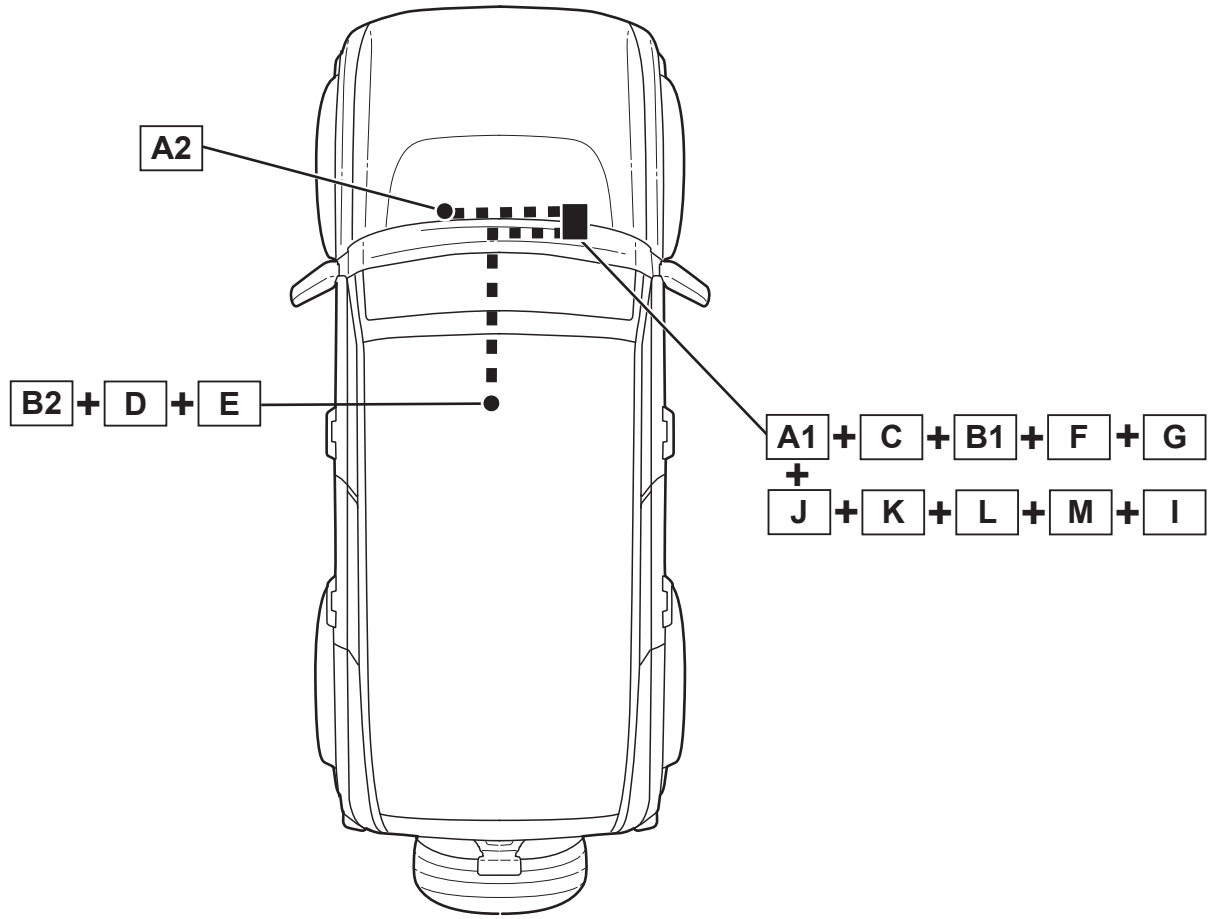

Important

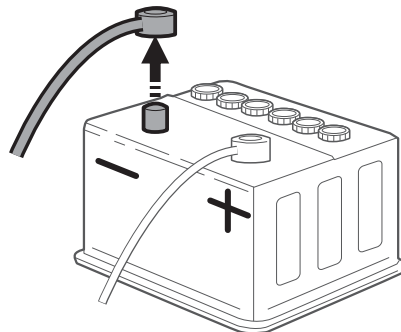

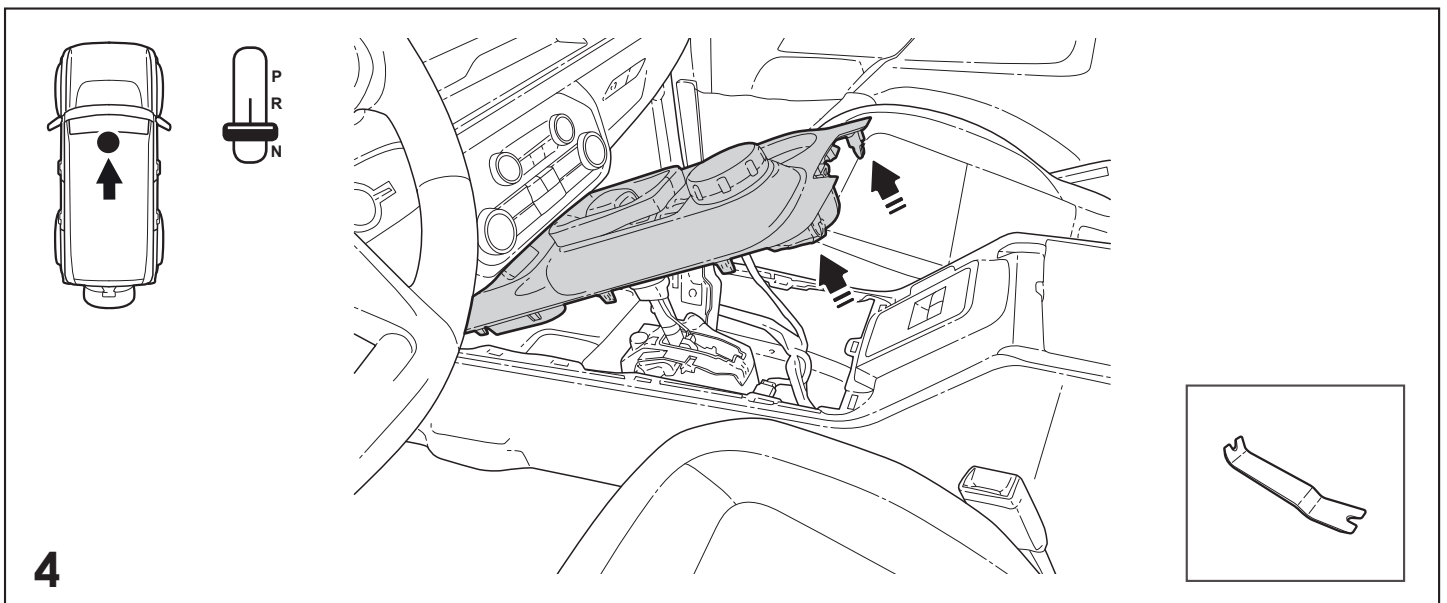
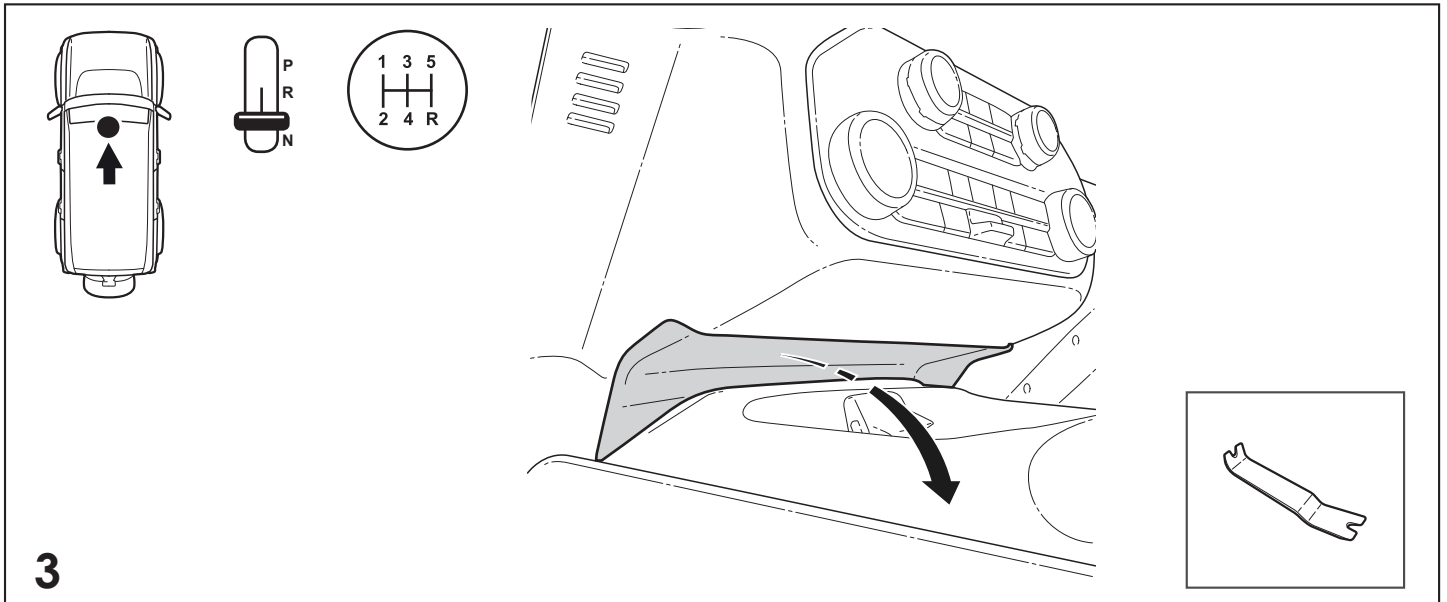
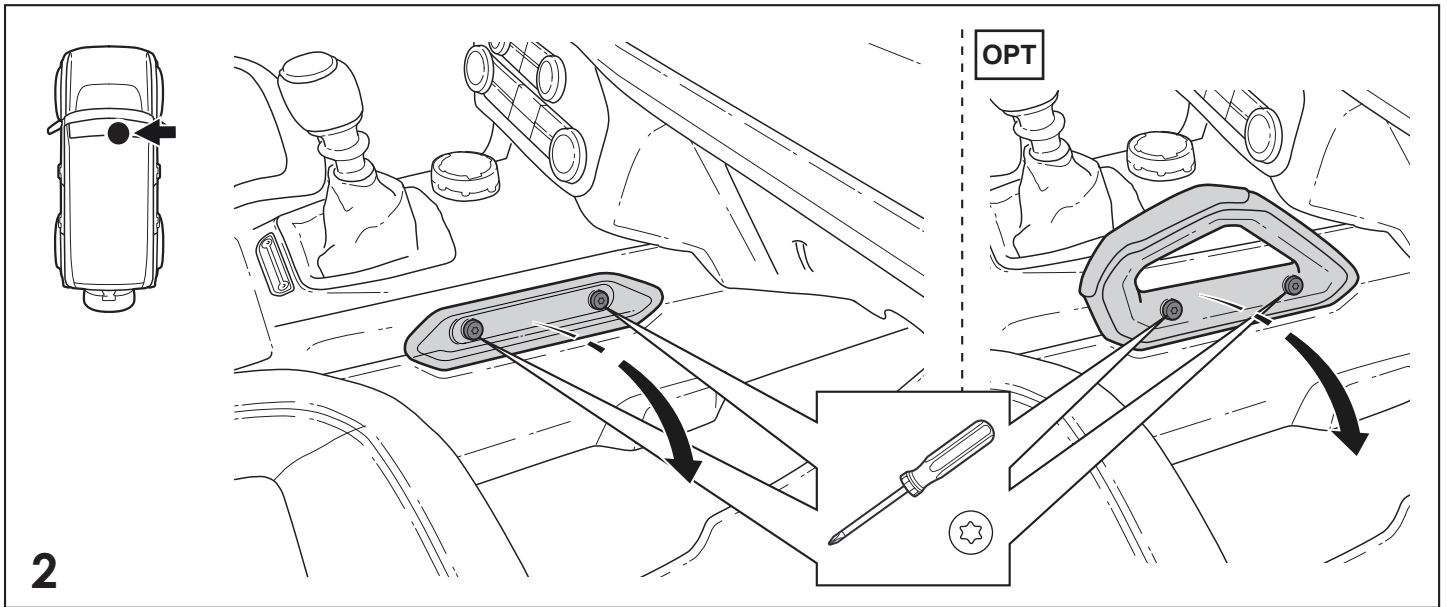

1

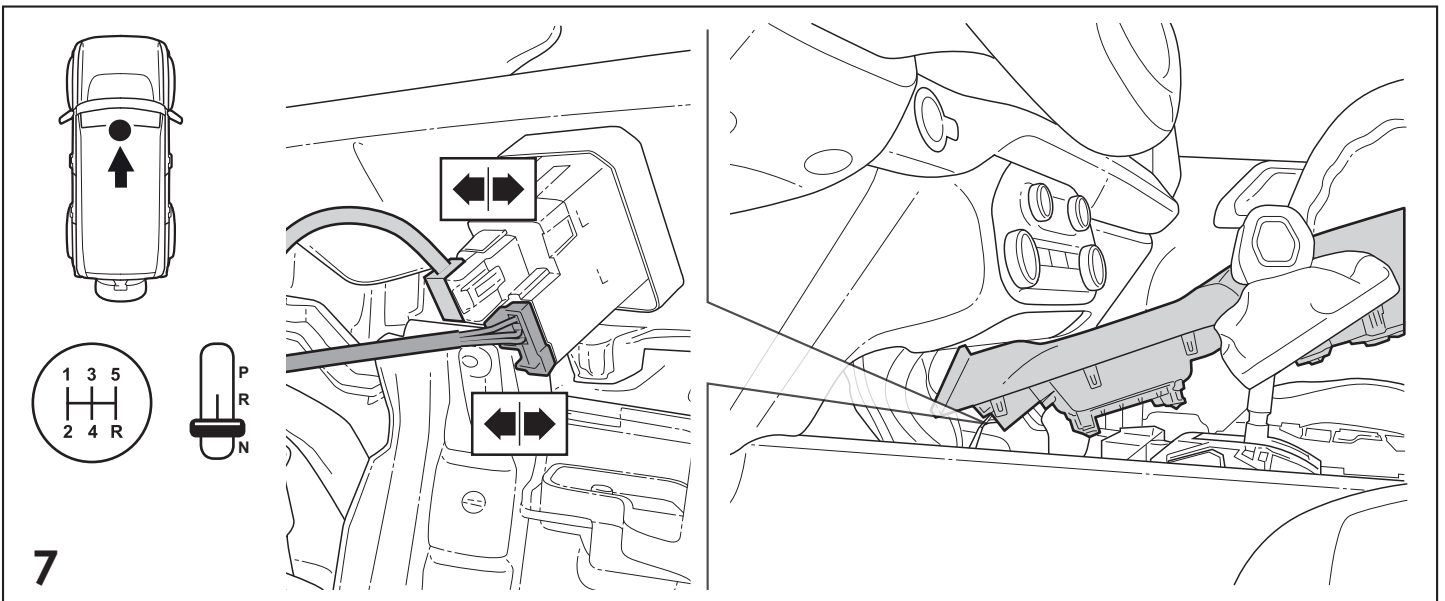
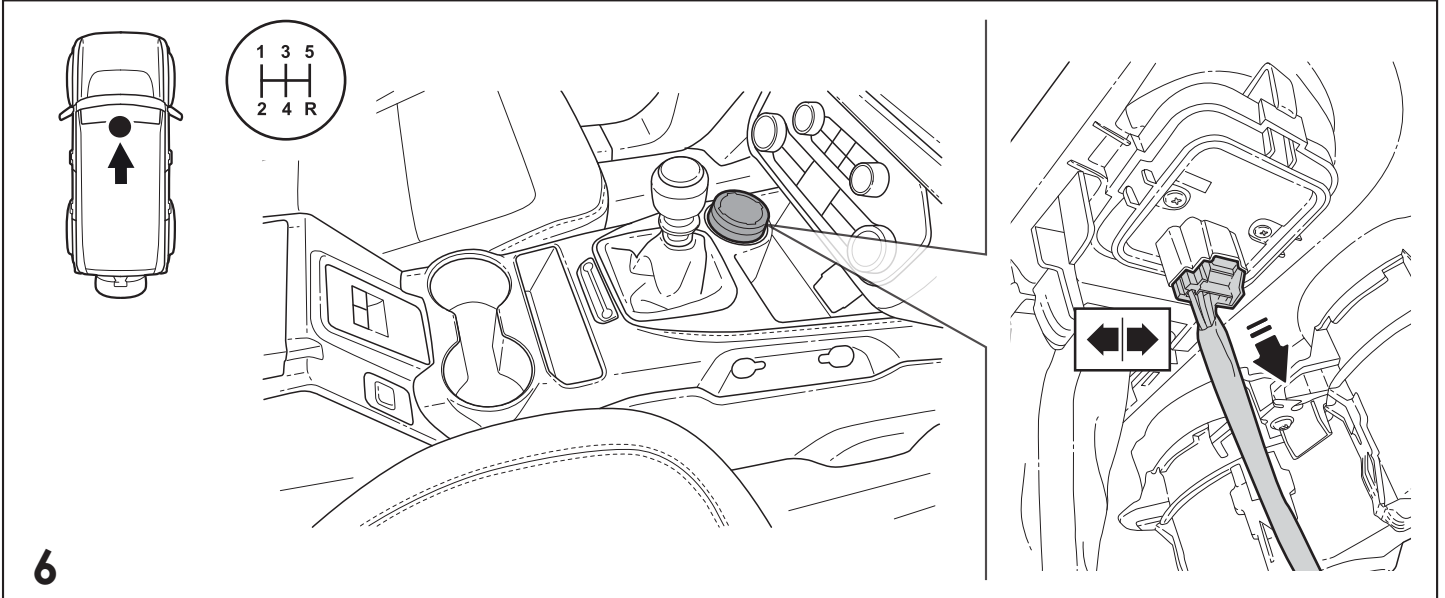
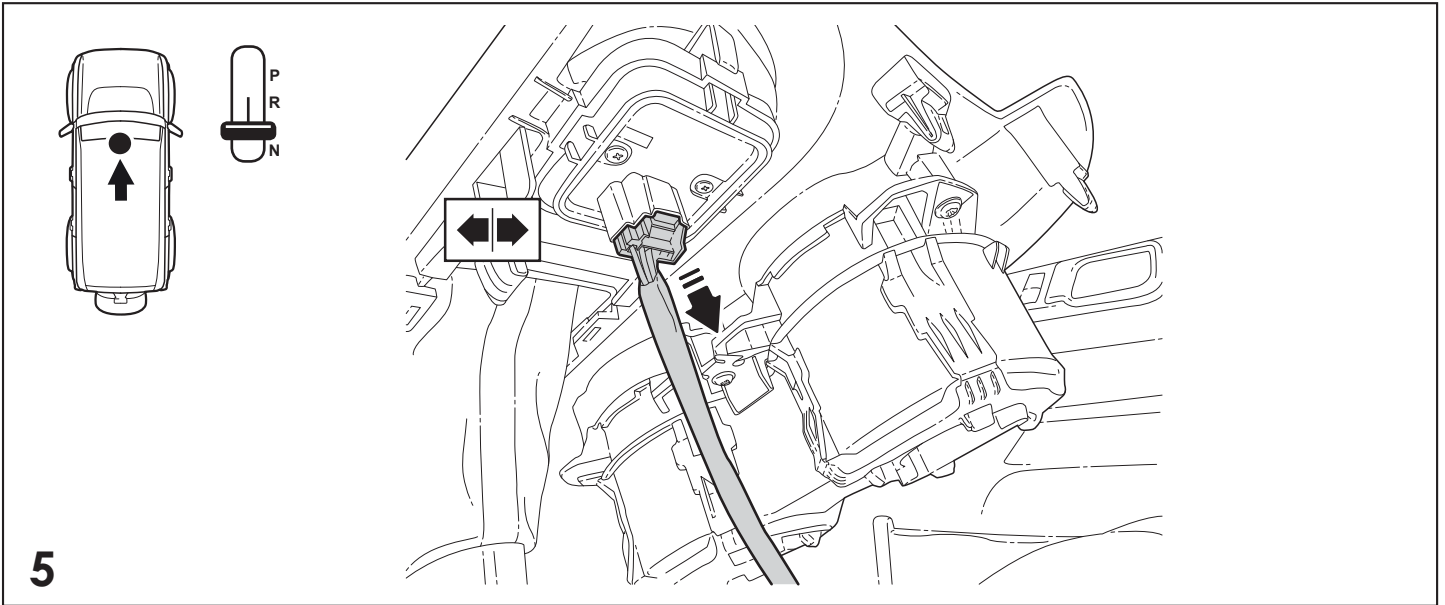

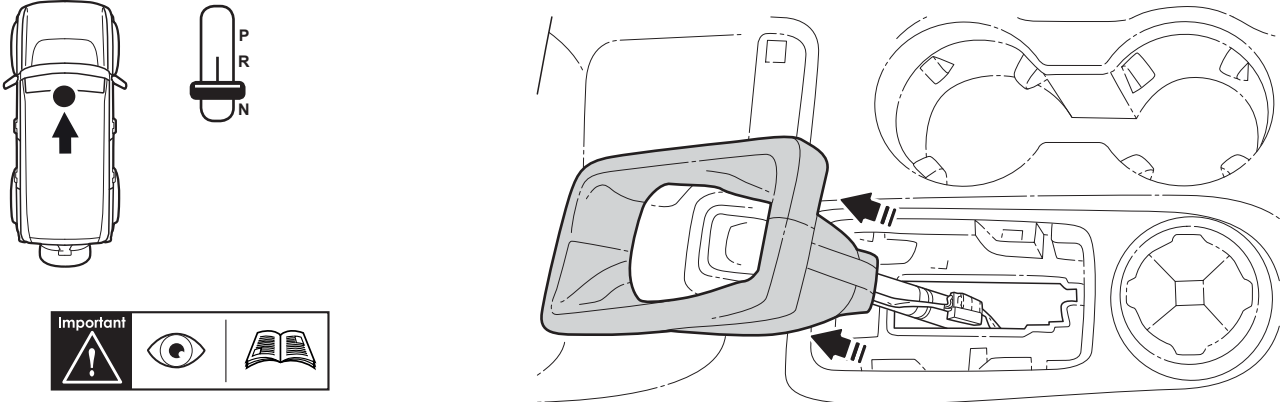





**Important**   



**EN:** Remove according to manufacturers recommendations.  
**FR:** Retirer selon les recommandations du fabricant.  
**ES:** Desmontar según las recomendaciones del fabricante

**8**

**Important**  

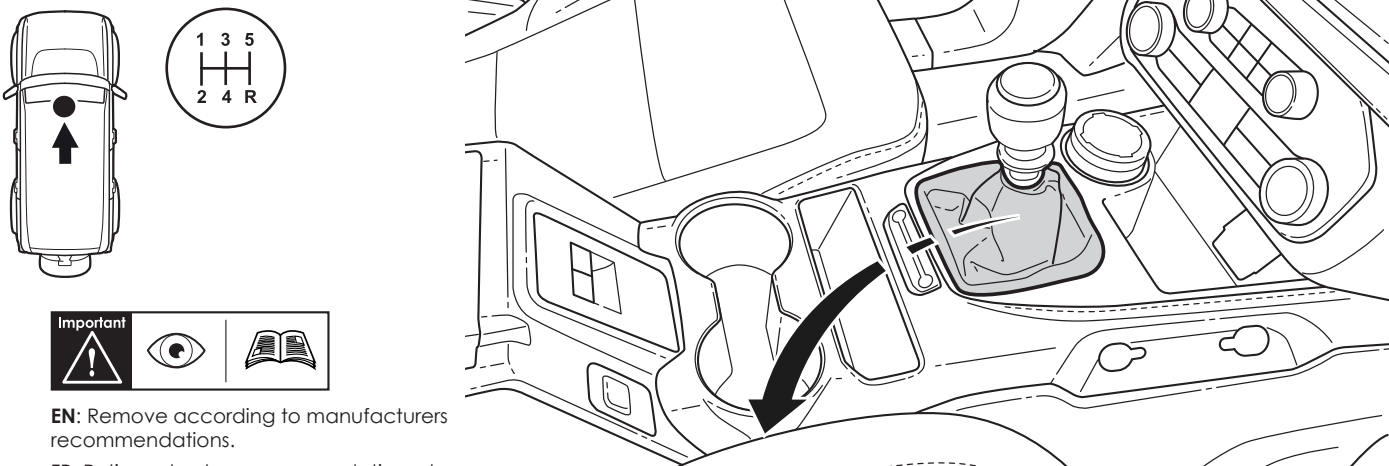
**EN:** Completely remove center console cover.  
**FR:** Retirer complètement le couvercle de la console centrale.  
**ES:** Retirar completamente la cubierta de la consola central







**Important**   

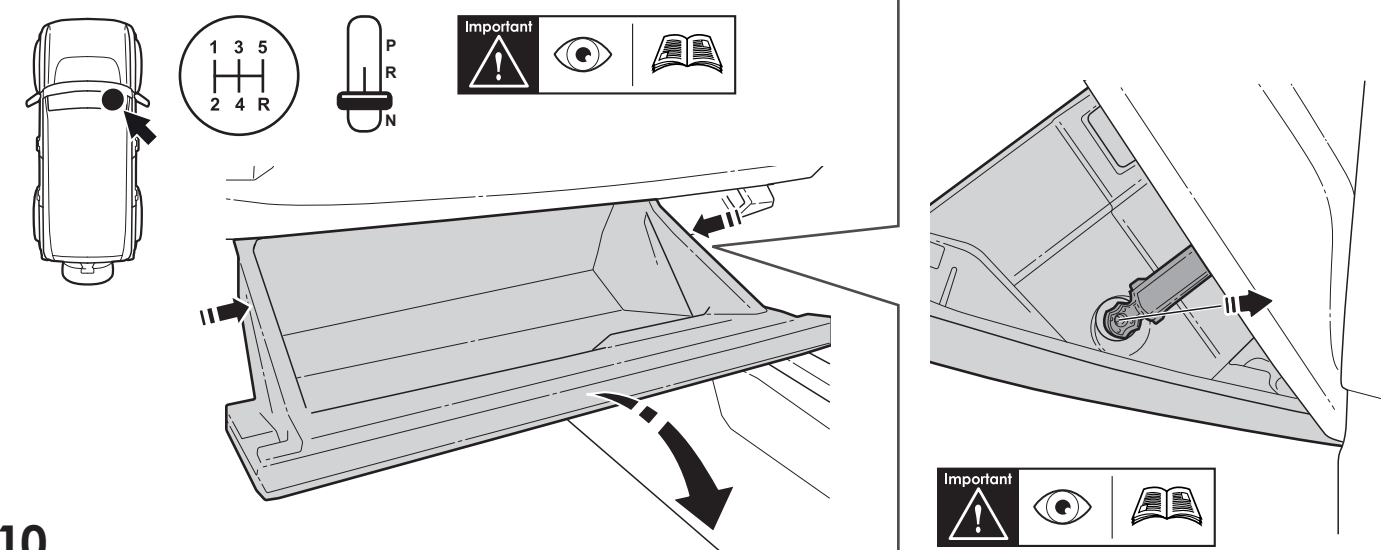

**EN:** Remove according to manufacturers recommendations.  
**FR:** Retirer selon les recommandations du fabricant.  
**ES:** Desmontar según las recomendaciones del fabricante

**9**

**EN:** Completely remove center console cover.  
**FR:** Retirer complètement le couvercle de la console centrale.  
**ES:** Retirar completamente la cubierta de la consola central



**Important**   

**Important**   

**10**

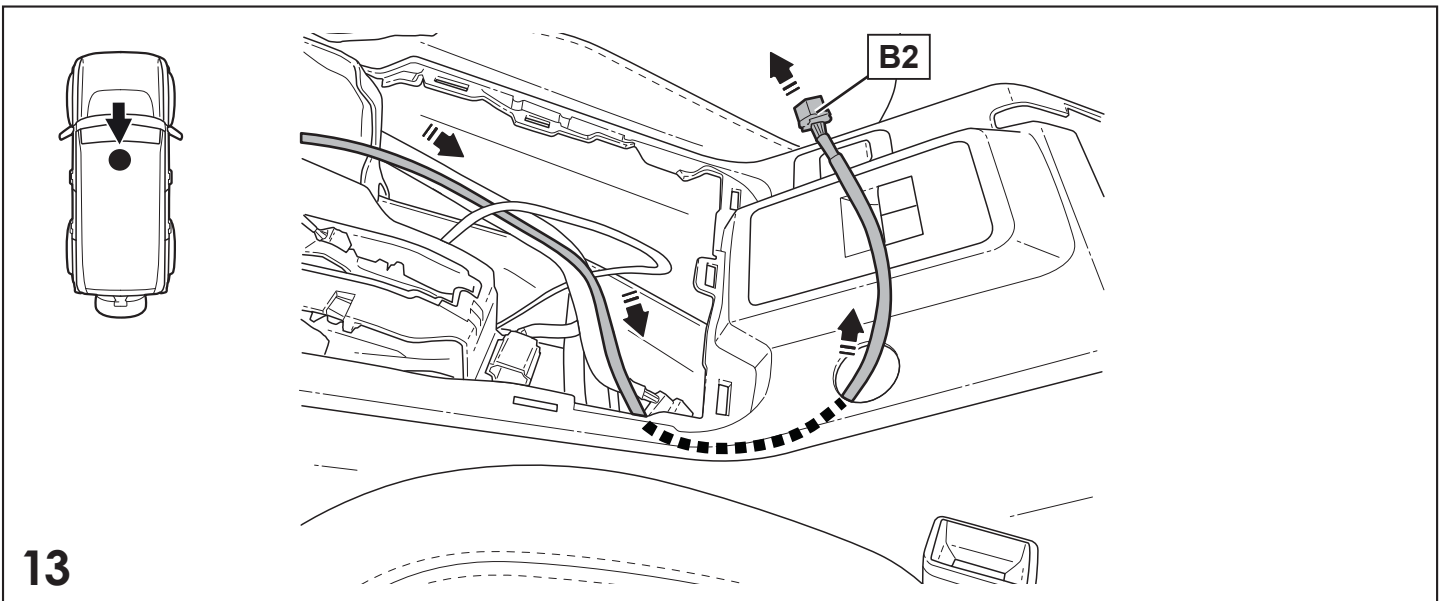
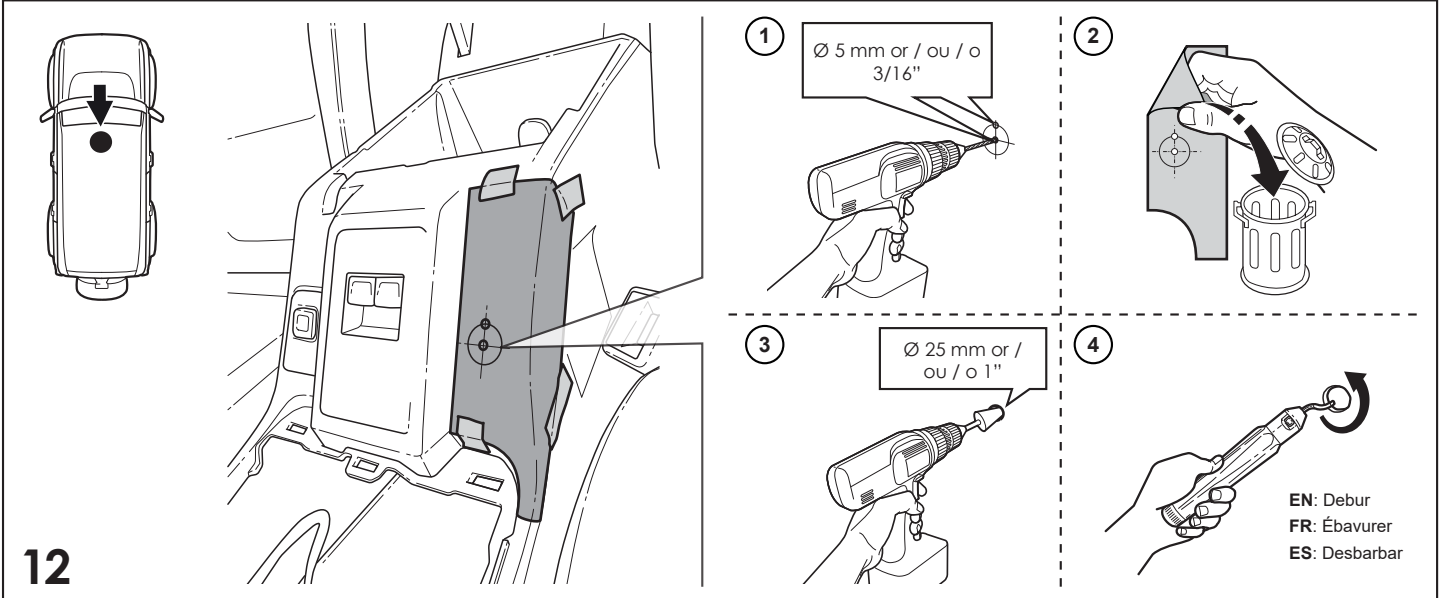
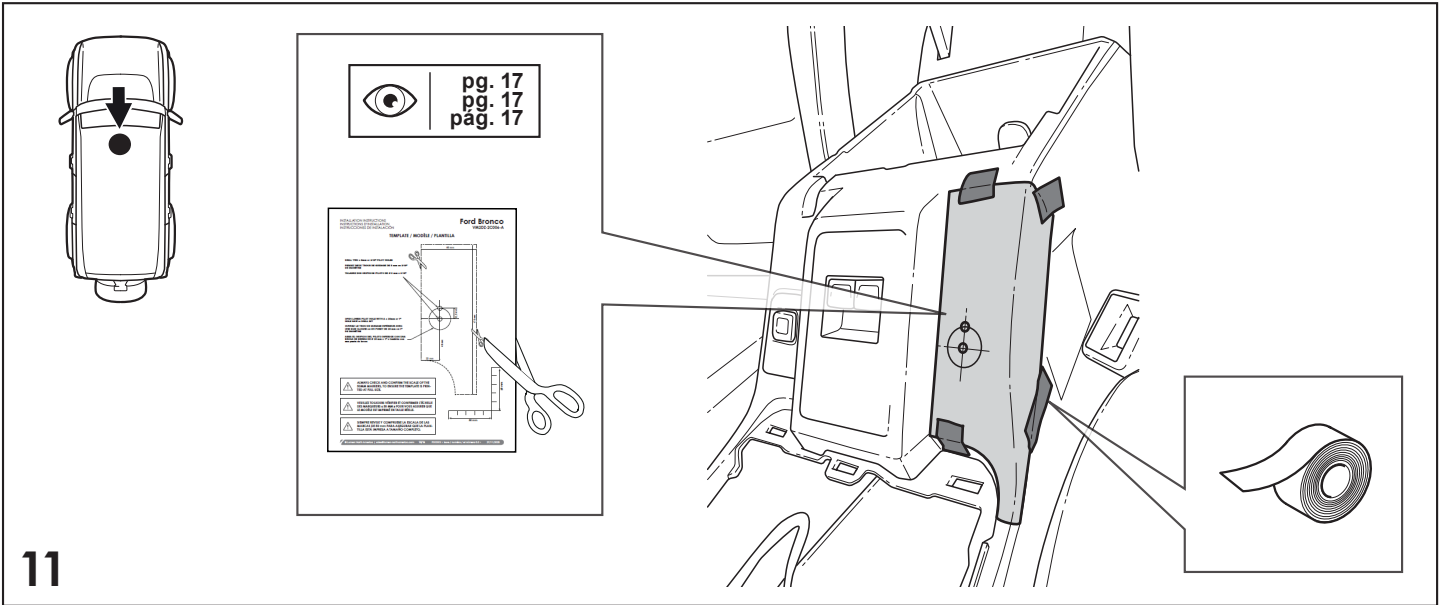

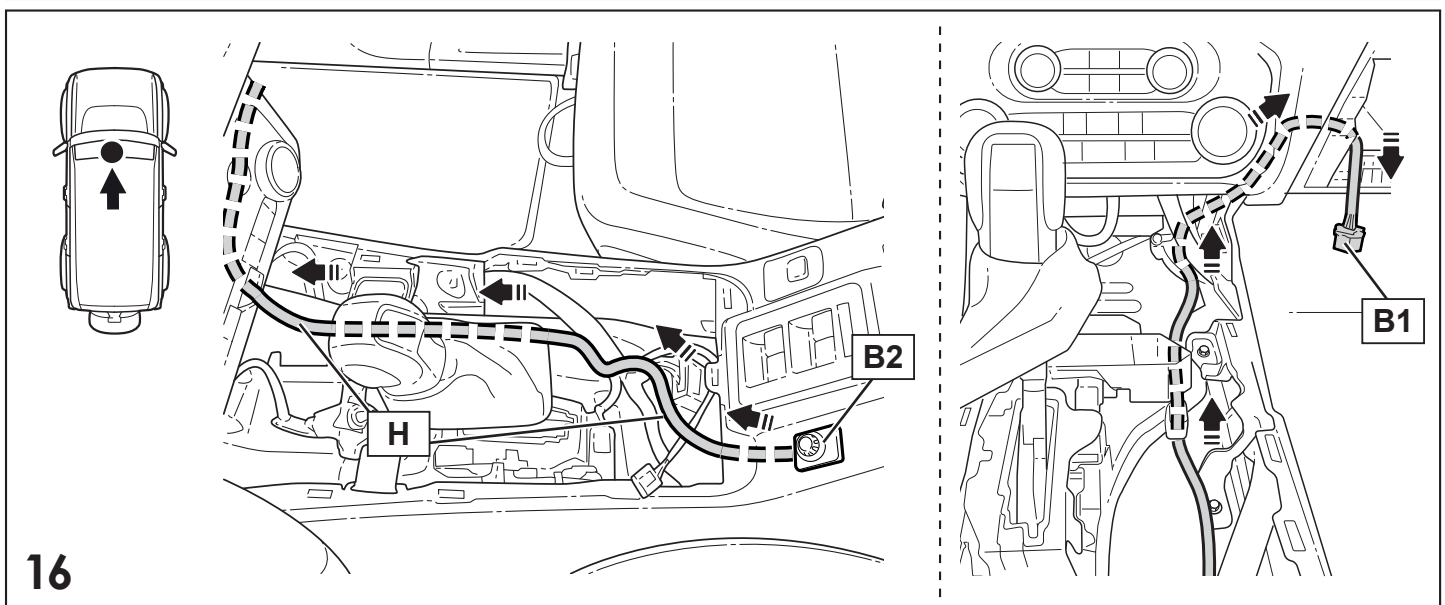
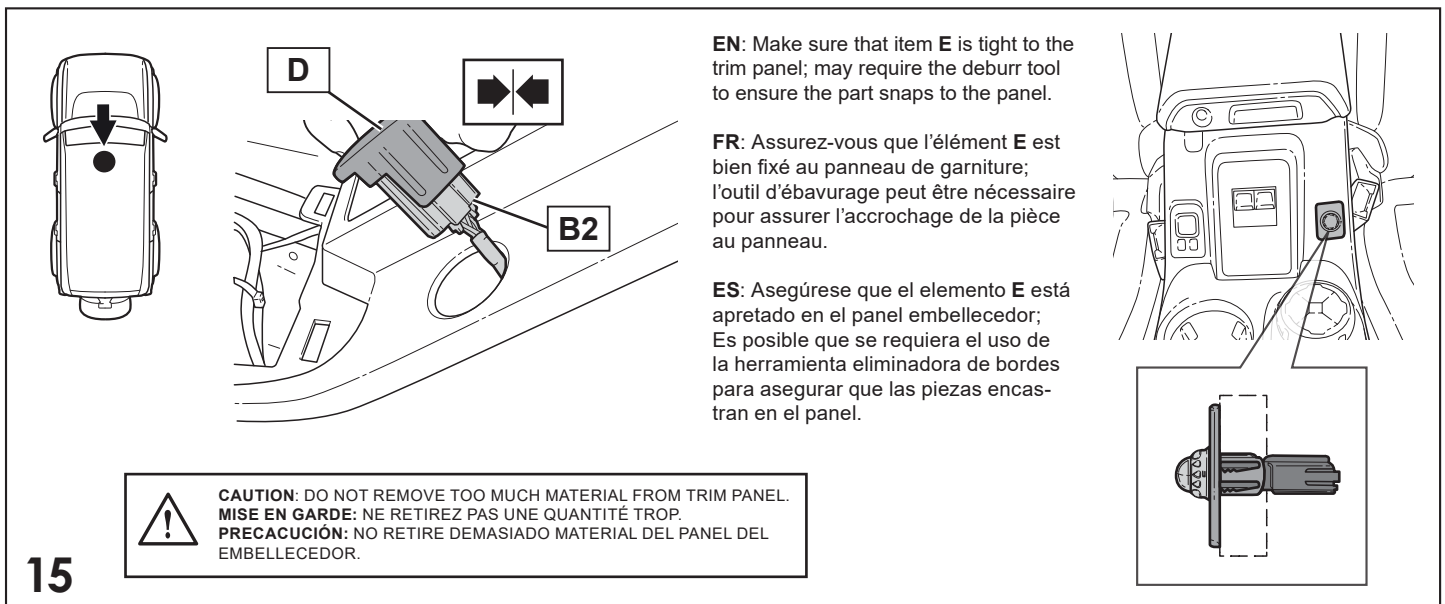
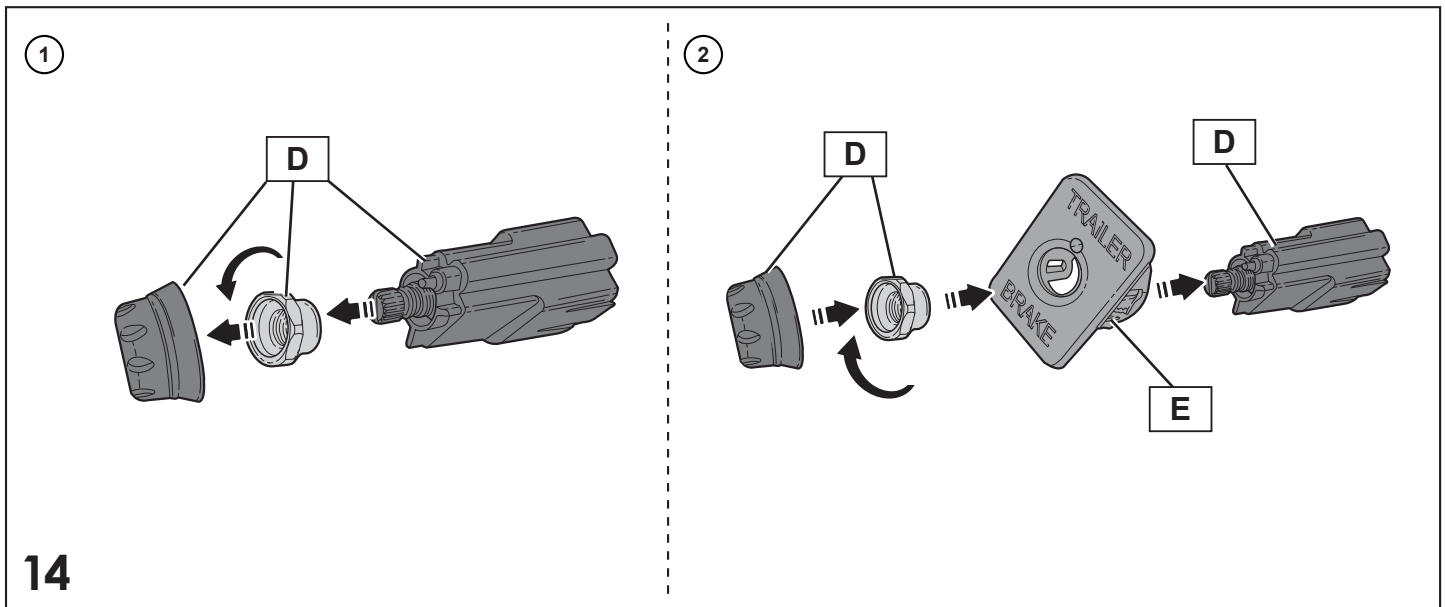

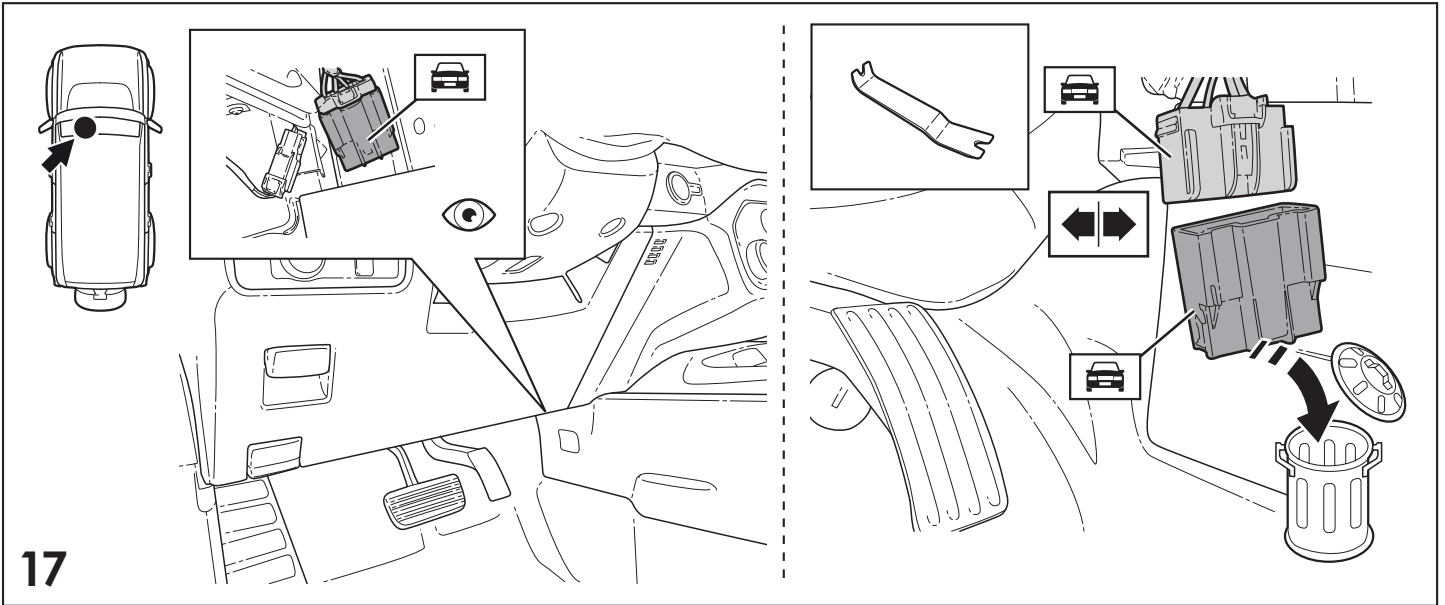

17

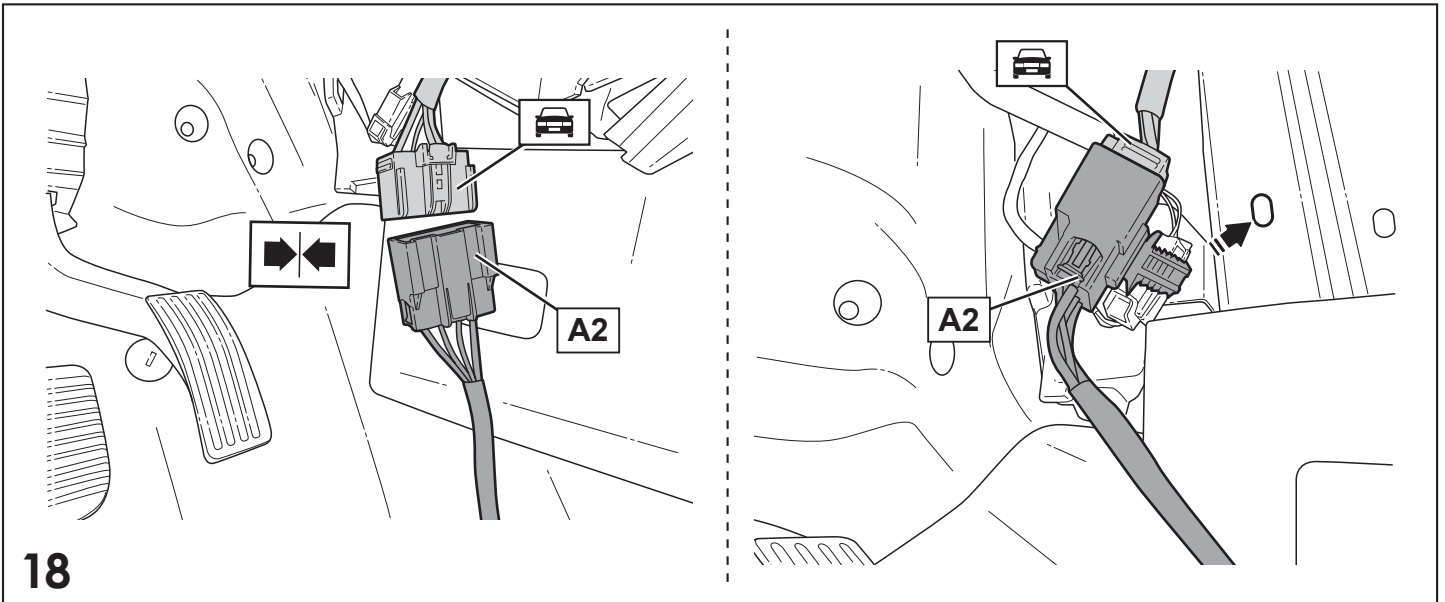

18

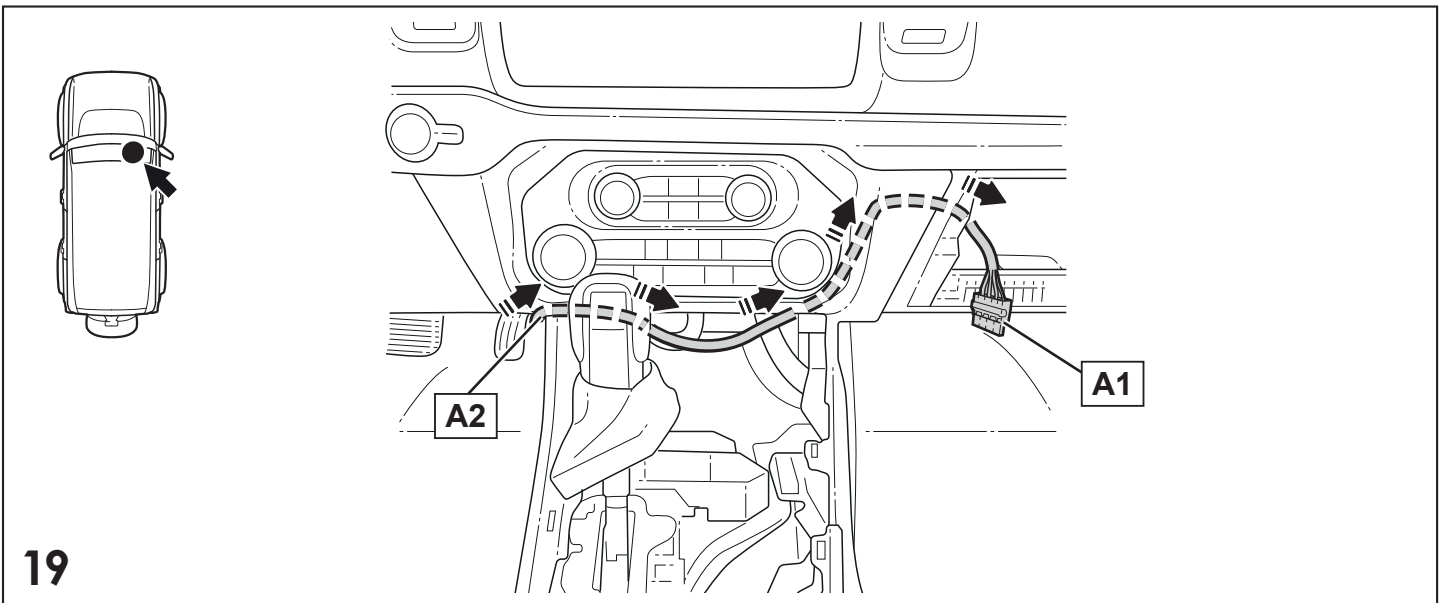

19

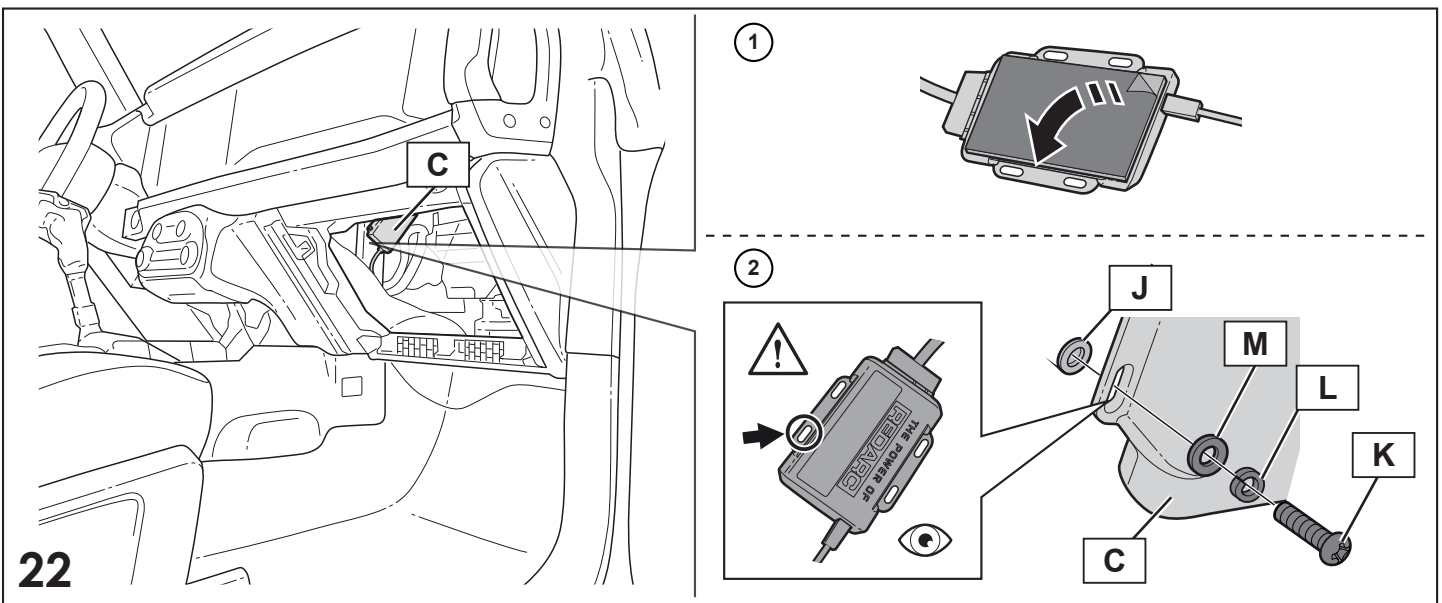
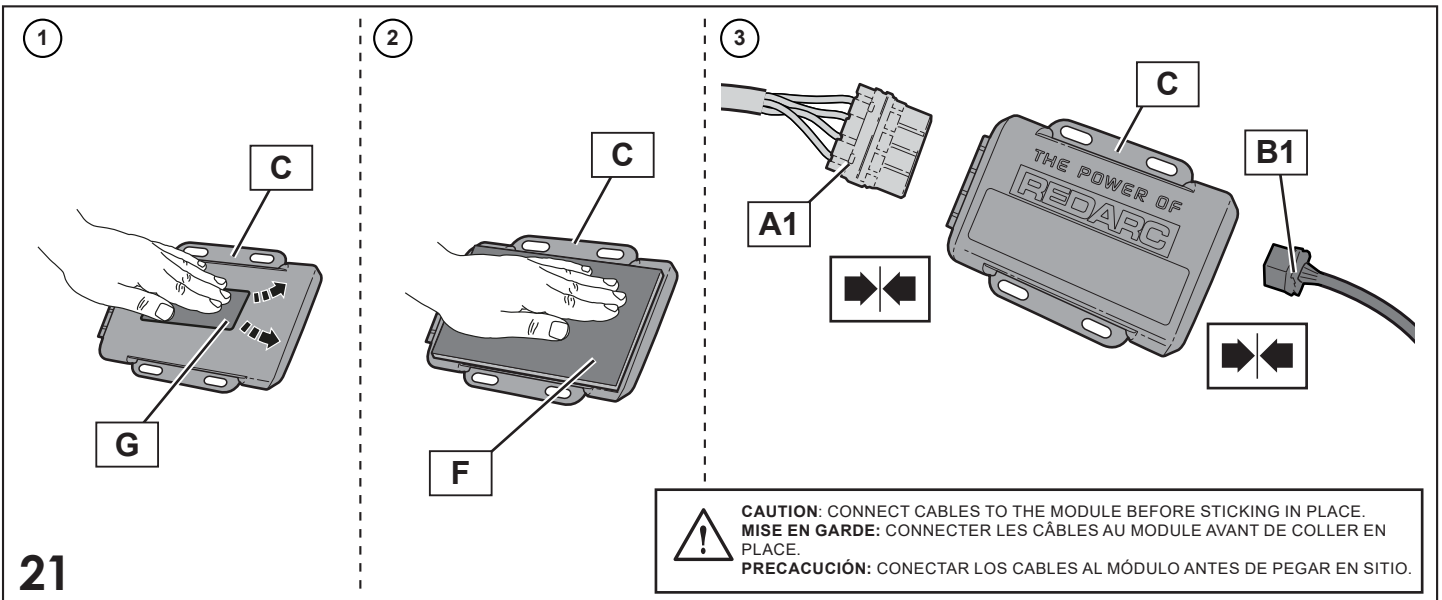
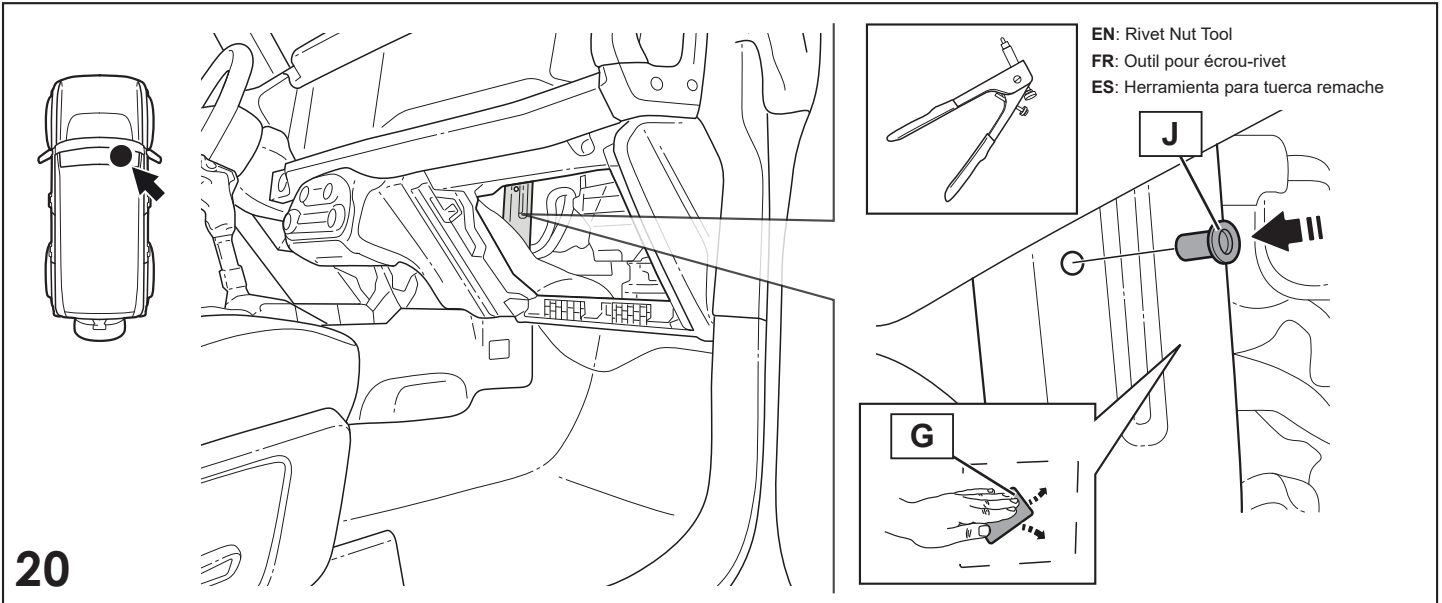

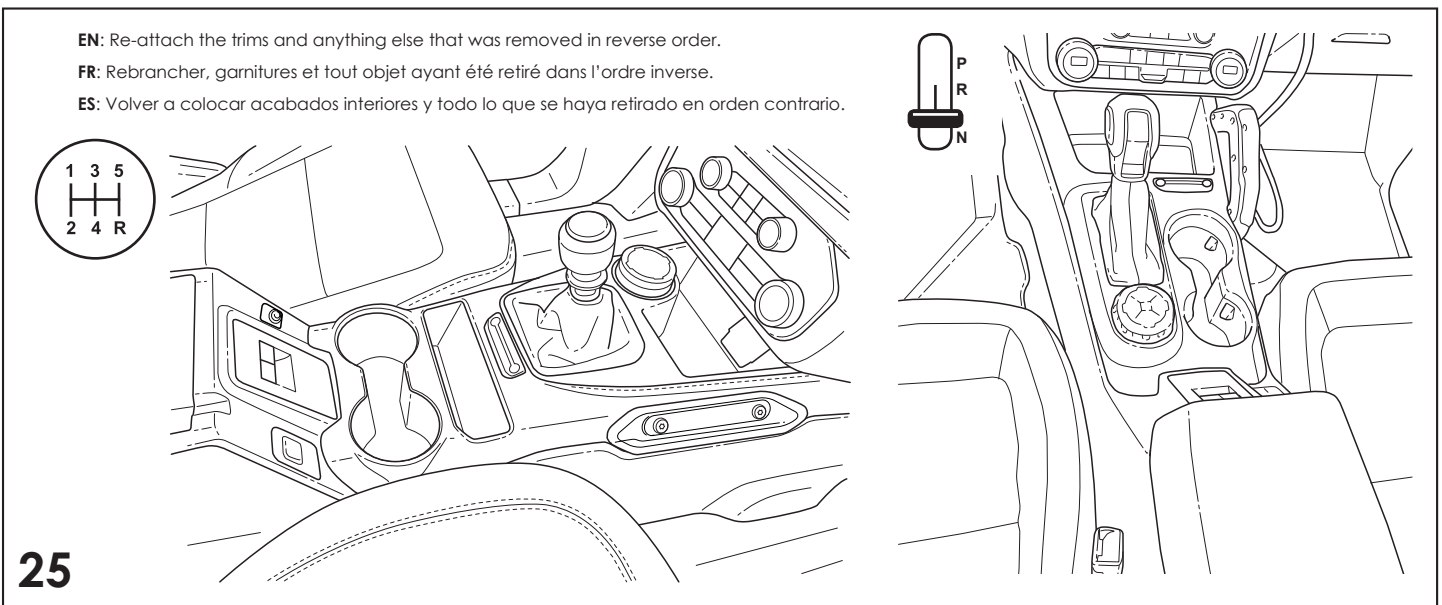
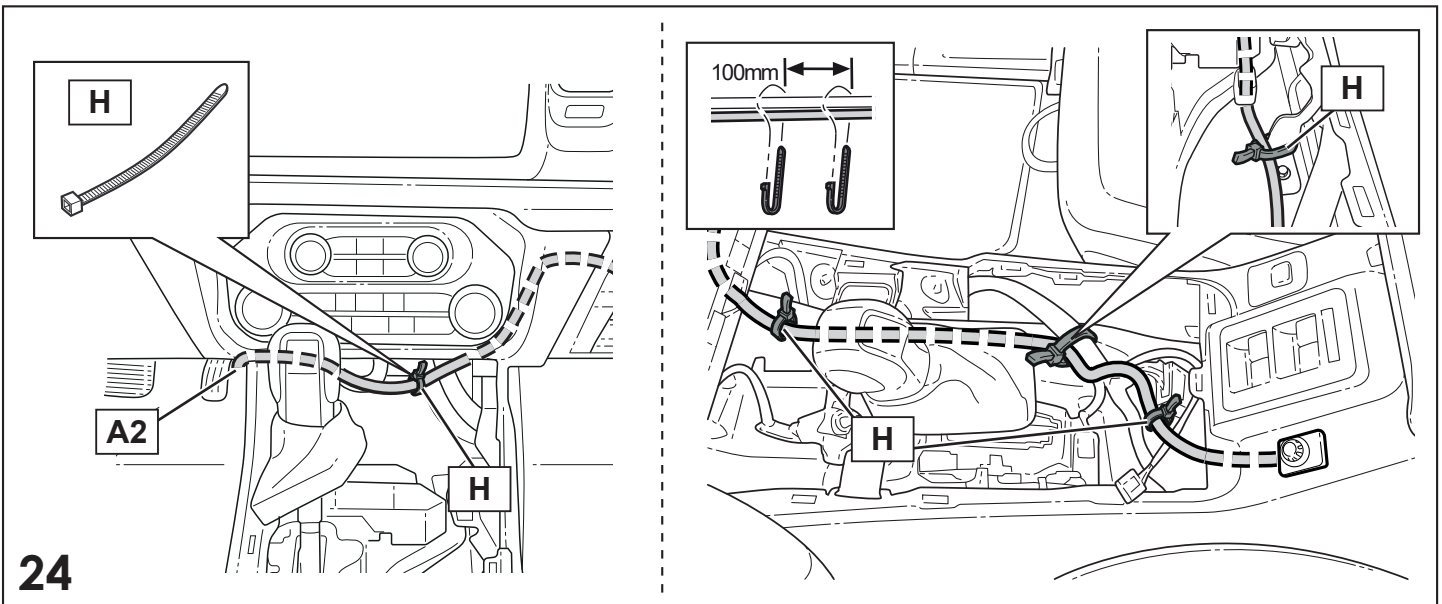
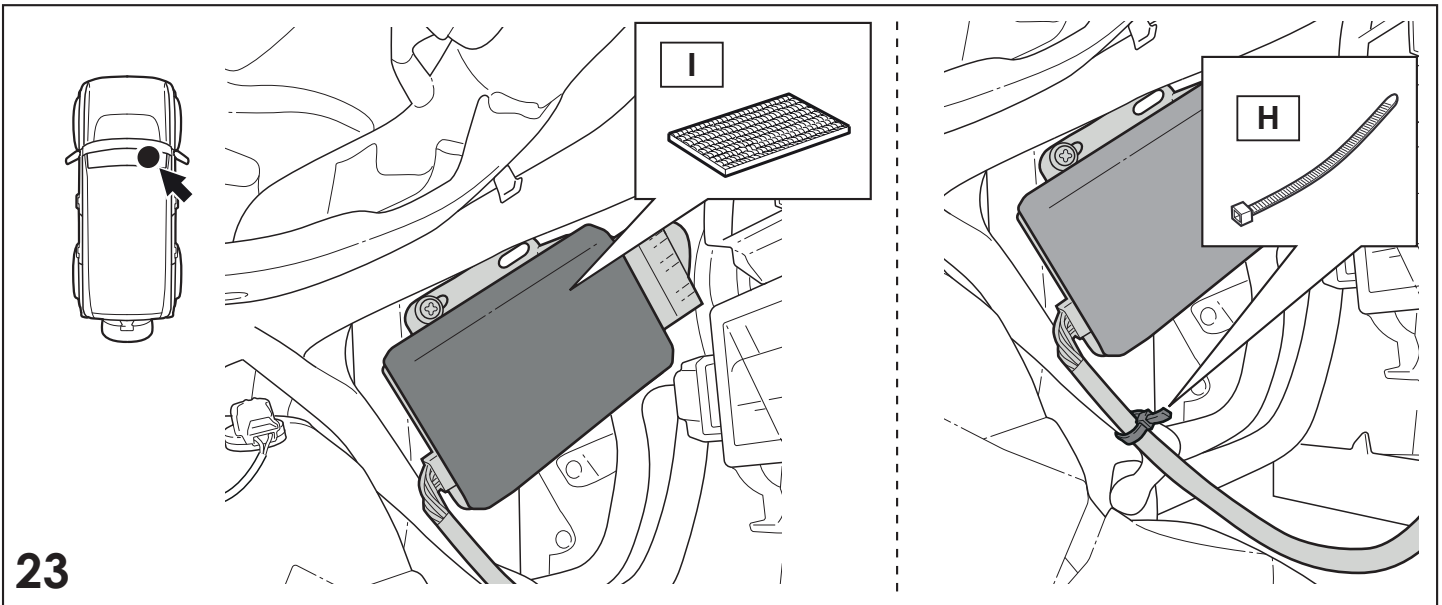

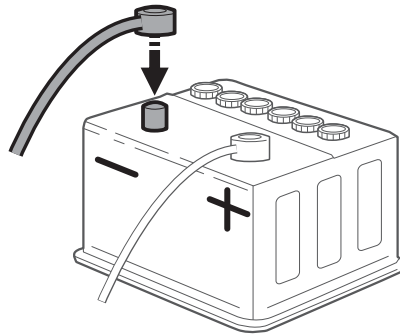

26

**EN:** Owner's Manual  
**FR:** Manuel du propriétaire  
**ES:** Manual de uso

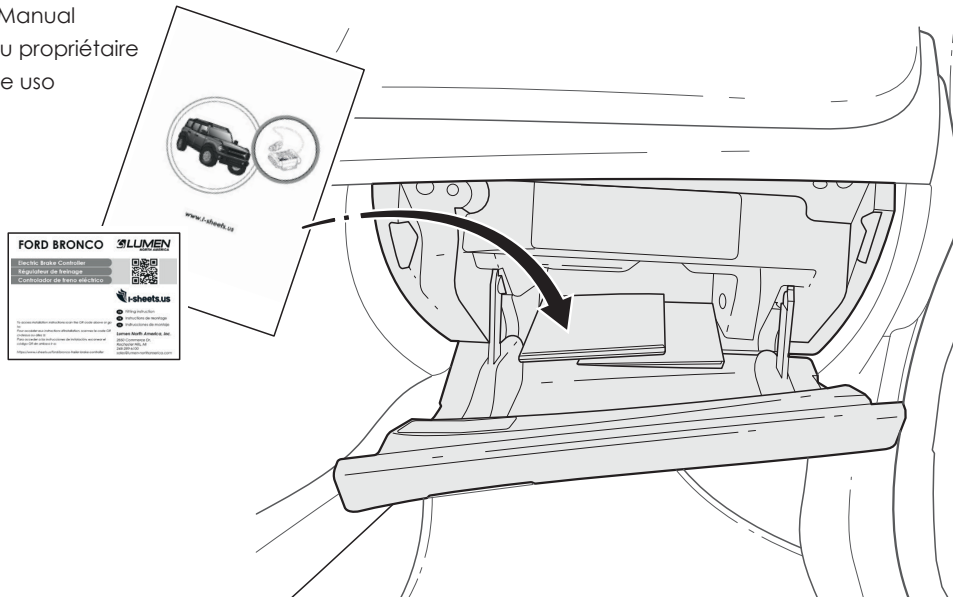

**EN:** Check part after installation using steps from page 15  
**FR:** Vérifiez la pièce après l'installation en suivant les étapes indiquées à partir de la page 15  
**ES:** Revise la pieza después de su instalación utilizando los pasos de la página 15

27

		REMOTE HEAD TÊTE DISTANTE CABEZA REMOTA	REMOTE HEAD LED VOYANT DE LA TÊTE DISTANTE LED DE CABEZA REMOTA	TEST LIGHT LUMIÈRE D'ESSAI LUZ DE PRUEBA
	No test light Pas de lumière d'essai Sin luz de prueba		Off Off (Arrêt) Apagado	Off Off (Arrêt) Apagado
<b>TEST LIGHT CONNECTED / LUMIÈRE D'ESSAI CONNECTÉE / LUZ DE PRUEBA CONECTADA</b>				
1		 Fully Counter Clockwise Entièrement pivoté dans le sens anti-horaire A la izquierda por completo	Green/Blue Flashing Vert/Bleu clignotant Papardeo en Verde/Azul <hr/> Blue - when active calibration is complete Bleu - lorsque l'étalonnage actif est terminé Azul - cuando la calibración activa ha terminado	Off Off (Arrêt) Apagado
2		 5	Green/Purple Flashing Vert/Violet clignotant Papardeo en Verde/Violeta <hr/> Blue/Red - when active calibration is complete Bleu/Rouge - lorsque l'étalonnage actif est terminé Azul/rojo - cuando la calibración activa ha terminado	Increasing Illumination Illumination progressive Aumentar iluminación
3		 Fully Clockwise Entièrement pivoté dans le sens horaire A la derecha por completo	Green/Red Vert/Rouge Verde/Rojo <hr/> Red - when active calibration is complete Rouge - lorsque l'étalonnage actif est terminé Rojo - cuando la calibración activa ha terminado	Fully Illuminated Entièrement éclairé Iluminado por completo
<b>MANUAL OVERRIDE / CORRECTION MANUELLE / ANULACIÓN MANUAL</b>				
4		 Fully Counter Clockwise Entièrement pivoté dans le sens anti-horaire A la izquierda por completo	Green/Red Vert/Rouge Verde/Rojo <hr/> Blue - when active calibration is complete Bleu - lorsque l'étalonnage actif est terminé Azul - cuando la calibración activa ha terminado	Faintly Illuminated Légèrement éclairé Débilmente iluminado
5		 5	Green/Purple Vert/Violet Verde/Violeta <hr/> Blue/Red - when active calibration is complete Bleu/Rouge - lorsque l'étalonnage actif est terminé Azul/rojo - cuando la calibración activa ha terminado	Increasing Illumination Illumination progressive Iluminación creciente
6		 Fully Clockwise Entièrement pivoté dans le sens horaire A la derecha por completo	Green/Red Vert/Rouge Verde/Rojo <hr/> Red - when active calibration is complete Rouge - lorsque l'étalonnage actif est terminé Rojo - cuando la calibración activa ha terminado	Fully Illuminated Entièrement éclairé Iluminado por completo
<b>MANUAL OVERRIDE / CORRECTION MANUELLE / ANULACIÓN MANUAL</b>				
7	Mode Change Proportional Modification Du Mode Proportionnel Cambio De Modo Proporcional → Manual Manuel Manual		Green/Blue Flashing Vert/Bleu clignotant Papardeo en Verde/Azul <hr/> Blue - when active calibration is complete Bleu - lorsque l'étalonnage actif est terminé Azul - cuando la calibración activa ha terminado	
8	Mode Change Manual Modification Du Mode Manuel → Proportional Proportionnel Proporcional Cambio De Modo Manual		Green Vert Verde	
9	Ensure System is in Proportional Mode for Customer Assurez-vous que le système est en mode Proportionnel pour le client Asegúrese que el sistema se encuentra en modo proporcional para el cliente		Green/Blue Flashing Vert/Bleu clignotant Papardeo en Verde/Azul <hr/> Blue - when active calibration is complete Bleu - lorsque l'étalonnage actif est terminé Azul - cuando la calibración activa ha terminado	
<b>REMOVE TEST LIGHTING / RETIREZ L'ÉCLAIRAGE D'ESSAI / ELIMINE LA LUZ DE PRUEBA</b>				

**EN** THIS PAGE INTENTIONALLY LEFT BLANK

**FR** CETTE PAGE EST INTENTIONNELLEMENT LAISSÉE EN BLANC

**ES** ESTA PÁGINA SE DEJA EN BLANCO INTENCIONADAMENTE

**TEMPLATE / MODÈLE / PLANTILLA**

**DRILL TWO  $\varnothing$  5mm or 3/16" PILOT HOLES**

**PERCEZ DEUX TROUS DE GUIDAGE DE 5 mm ou 3/16" DE DIAMÈTRE**

**TALADRE DOS ORIFICIOS PILOTO DE  $\varnothing$  5 mm o 3/16"**

**OPEN LOWER PILOT HOLE WITH A  $\varnothing$  25mm or 1" HOLE SAW or DRILL BIT**

**OUVREZ LE TROU DE GUIDAGE INFÉRIEUR AVEC UNE SCIE CLOCHE ou UN FORET DE 25 mm ou 1" DE DIAMÈTRE**

**ABRA EL ORIFICIO DEL PILOTO INFERIOR CON UNA BROCA DE SIERRA DE  $\varnothing$  25 mm o 1" o también con una punta de broca**

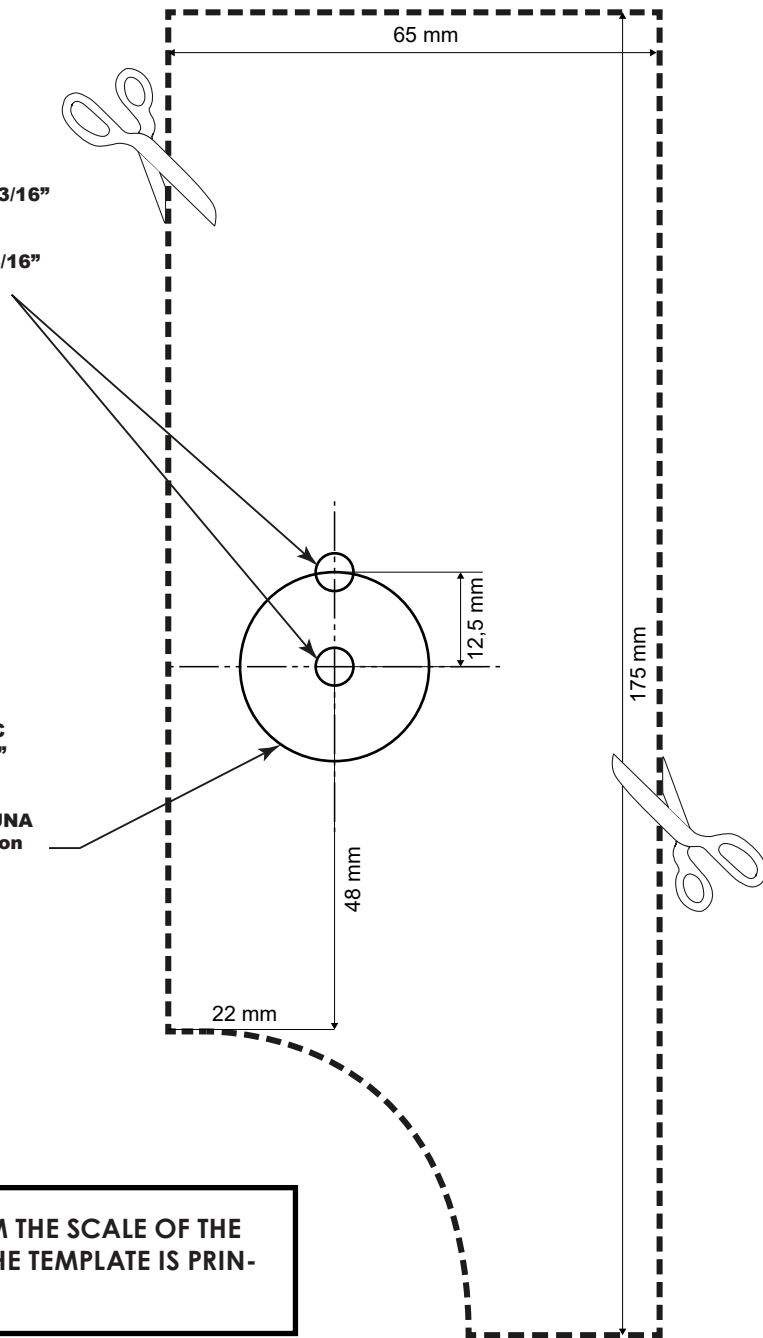

**ALWAYS CHECK AND CONFIRM THE SCALE OF THE 50MM MARKERS, TO ENSURE THE TEMPLATE IS PRINTED AT FULL SIZE.**



**VEUILLEZ TOUJOURS VÉRIFIER ET CONFIRMER L'ÉCHELLE DES MARQUEURS « 50 MM » POUR VOUS ASSURER QUE LE MODÈLE EST IMPRIMÉ EN TAILLE RÉELLE.**



**SIEMPRE REVISE Y COMPRUEBE LA ESCALA DE LAS MARCAS DE 50 mm PARA ASEGURAR QUE LA PLANTILLA ESTÁ IMPRESA A TAMAÑO COMPLETO.**